



MIXER
SAMSON®

MPL 2242

Produced by *On The Right Wavelength* for Samson Technologies Corp.

Written by Howard Massey
Layout and graphic design by Linda E. Law

Copyright 1993, Samson Technologies Corp.

Printed January 1993

Samson Technologies Corp.
262 Duffy Avenue
Hicksville, NY 11801
Phone: 516-932-1062
Fax: 516-932-3815

Table of Contents

Introduction 1

MPL 2242 Features 1

Guided Tour 3

Overview 3
Mono and stereo channels 4
Main section 6
Jackfield 8

Connecting the MPL 2242 10

Balanced connectors 10
Unbalanced connectors 10
Mic connectors 10
Insert connectors 12
Using a patch bay 12

Grounding Techniques 16

MPL 2242 Signal Flow 17

Setting the Correct Gain Structure 18

Bussing, Submixing, and Channel Muting 20

Pan/Balance 21

Equalization 23

Auxiliary Sends and Returns 24

Channel Inserts 25

PFL and IPS 26

Changing the MPL 2242 from Rack-Mount to TableTop 27

Applications 28

Using the MPL 2242 as a main live mixer 28
Using the MPL 2242 as an onstage monitor mixer 29
Using the MPL 2242 as a keyboard submixer 30
Using the MPL 2242 as a recording mixer 31

Specifications 33

Congratulations on purchasing the Samson MPL 2242 mixer! In this manual, we'll take you on a guided tour through all the features of this powerful and flexible device, and we'll tell you how to get the most out of the MPL 2242 in your particular environment. If this is your first mixer, we're confident that you'll find the information in these pages valuable—read them carefully before proceeding further. If, on the other hand, you've had some previous experience with mixers and dislike reading manuals—well, we have to admit that the 2242 was designed so you folks can start using it right away—but we still suggest you take some time out first to go through these pages so you can fully understand how we've implemented a number of unique features.

We'll start with system features and an overview of the MPL 2242, followed by a guided tour of its front and rear panels. Then we'll describe how the MPL 2242 should be connected to your existing equipment (including wiring diagrams) and talk about the important topics of signal flow, gain structure, and grounding techniques. Next, we'll cover a number of specific MPL 2242 features (such as bussing, panning, equalization, auxiliary sends and returns, using channel inserts, soloing, and converting from rackmount to tabletop use) in detail. Finally, we'll wrap things up with a series of applications notes describing how you can use the MPL 2242 for both live performance and recording.

Oh, and one last thing—don't forget to fill out and mail in the enclosed warrantee card! This will enable you to receive online technical support and will allow us to send you updated information about other Samson products in the future.

MPL 2242 Features

“MPL” stands for “Microphone/Program/Line” and the name describes the broad range of signals which can be handled by this powerful console. In fact, the compact design of the MPL 2242 belies an extraordinary versatility. Add excellent sound quality to the equation, and you've got a product which is equally useful as a live performance mixer, a keyboard submixer, or even a main recording mixer (you'll find descriptions of each of these applications at the conclusion of this manual). Here are some of the MPL 2242's main features:

- 22 input channels, including 6 stereo channels. The 10 monophonic channels provide balanced inputs that can be used for microphone or line-level input, and the 6 stereo channels are ideal for line-level sources such as outboard signal processors; CD players; tape or cassette recorders; stereo drum machines; keyboards; and MIDI tone modules.
- 4 *buss* outputs and a balanced main stereo mix output (a “buss” is simply a pathway through which a signal can be routed). Busses 1 and 3 are normalled to the left mix output and busses 2 and 4 are normalled to the right mix output. This flexible design allows you to easily mute selected channels and/or to create submixes within your main mix.
- 6 auxiliary sends and 4 stereo auxiliary returns (which can be used as 8 monophonic returns). Aux 1 is pre-fader and pre-equalizer, making it ideal for use as a headphone or monitor cue mix; all other auxiliary sends are post-fader and post-equalizer. Each channel can route signal to up to four auxiliary sends simultaneously.

Introduction

- Independent 4-band equalization for each channel, with 15 db of cut or boost for low (80 Hz) and high (12 kHz) frequencies, and 12 db of cut or boost for low mid (800 Hz) and high mid (2.5 kHz) frequencies.
- Constant level pan controls for placing each monophonic channel in the left-right stereo spectrum as well as balance controls for each stereo channel and aux return that allow you to blend the relative levels of stereo inputs.
- As an alternative to standard *Pre Fade Listen (PFL)* soloing for each channel, the MPL 2242 also provides true *In Place Soloing (IPS)*. The IPS feature allows you to isolate a single channel, post-fader and post-EQ, in its proper stereo position and with all effects in place. PFL allows headphone monitoring of individual channels, pre-fader (but still post-EQ).
- Channel inserts are provided for each of the 10 monophonic input channels, enabling you to use outboard signal processors such as outboard equalizers, compressor/limiters, or noise gates in a standard “effect loop.”
- The MPL 2242 can be mounted in any standard 19” rack (taking nine rack spaces) or effortlessly converted for tabletop use. When rack-mounted, its connector panel rotates to the rear for easy accessibility.
- The provision of 48v phantom power makes it possible to plug high-quality condenser microphones directly into the MPL 2242, without the need for expensive and cumbersome external power supplies.
- A flexible metering system allows you to view at a glance the levels of either of the two buss pairs, as well as phantom power and IPS or PFL status and level.
- An independent front-panel headphone output with dedicated volume control and the ability to monitor either or both of the two buss pairs. Channels that are soloed in IPS or PFL mode are also routed directly to the headphone output.
- Input trims for each mono channel are continuously adjustable from +4 to -50 db (+4 to -30 db for stereo channels), making it possible to use the MPL 2242 with a wide variety of signal sources and outboard equipment.
- Center detents for all pan, balance, and EQ controls as well as detented 0 db fader points, making it easy to use the MPL 2242 even in low-light situations such as live performance.
- Peak input LEDs for each channel, showing you when an input signal is overloading or near overloading (these illuminate -5 db prior to distortion).
- Custom hybrid circuitry that places each channel’s mic preamp and four-band equalizer on the same circuit board. This “low capacitance” design results in less noise, reduced crosstalk, and extended frequency response—in other words, the MPL 2242’s sound stacks up to that of some of the best mixers around!
- Last but certainly not least, an affordable price. The MPL 2242 has been designed from the ground up to provide versatility and excellent sound quality without breaking the bank.

Guided Tour - Overview

The following illustration shows an overview of the front panel of the MPL 2242:

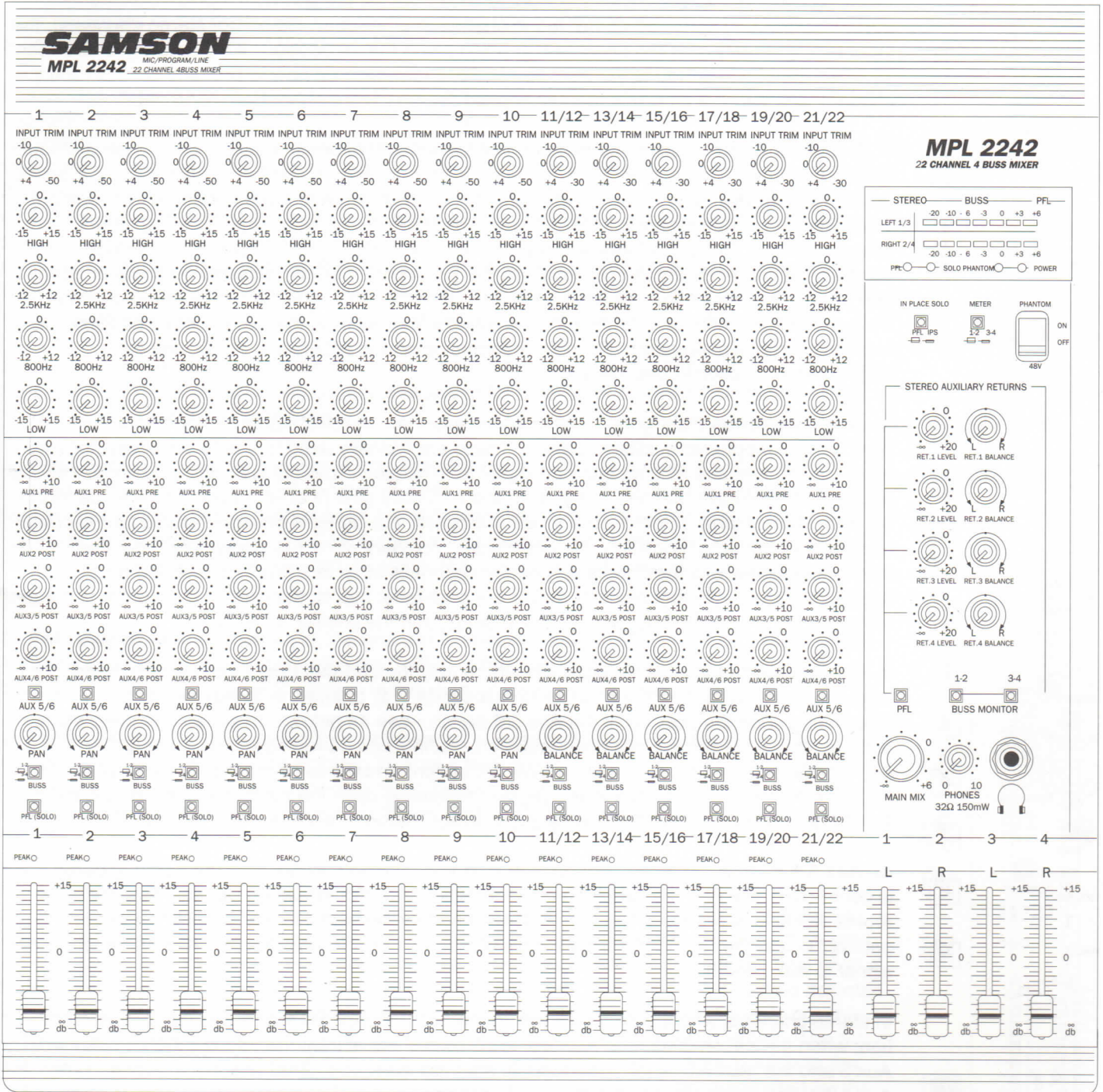

Mono channels

Stereo channels

Main section

Guided Tour - Mono and Stereo Channels

Let's start our guided tour by examining the various controls provided by each mono and/or stereo channel:

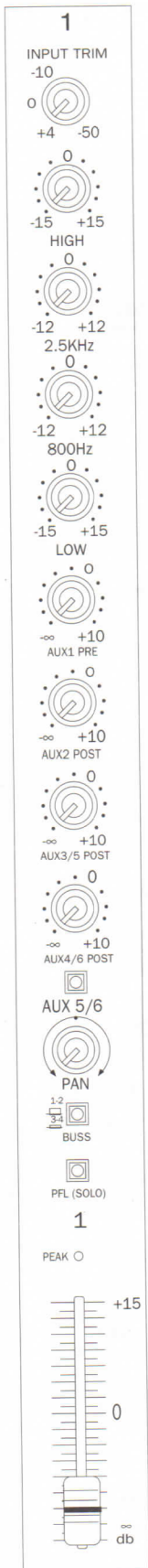

1

1: Input trim (black) - This knob determines the input level of the connected mic or line signal. In stereo channels, it determines the input level of both the left and right inputs. Continuously adjustable from +4 db to -50 db (for mono channels) or +4 db to -30 db (for stereo channels), the input trim is at unity gain (no boost or cut) when set to the +4 position. The input signal is boosted when the trim is turned to the right of +4. For information on how to properly set this for each channel, see the section in this manual entitled "Setting The Correct Gain Structure."

2

2: Equalizer (blue) - These knobs determine the amount of boost or attenuation in each of four frequency areas. The high and low frequency knobs provide 15 db of cut or boost at 12 kHz and 80 Hz, respectively, with shelving-type control. The high mid and low mid frequency knobs provide 12 db of cut or boost at 2.5 kHz and 800 Hz, respectively, with a bell (peaking) curve. In stereo channels, the EQ settings affect both the left and right inputs, although the signals remain separate. A center detent in each knob (at the 12 o'clock position) indicates no boost or attenuation (that is, flat response). As each knob is turned clockwise from the center detent position, the frequency area is boosted; as it is turned counterclockwise from the center detent position, the frequency area is attenuated. For more information on the application of EQ, see the "Equalization" section in this manual.

3

3: Auxiliary sends (light gray) - These knobs allow you to route signal to any four of the MPL 2242's six monophonic auxiliary outputs. These are typically used to create submixes (for example, a headphone cue mix) and to feed signal from single or multiple channels to outboard effects devices. At the 0 position, the signal is routed with unity gain (that is, no boost or attenuation). As each knob is turned clockwise from the 0 position, the signal is boosted; as it is turned counterclockwise from the 0 position, it is attenuated. Auxiliary send 1 is always pre-fade; that is, the level of the signal is determined solely by the channel's input trim and is unaffected by its fader and EQ settings. All other auxiliary sends are post-fade; that is, the level of the signals is determined by the channel's input trim, its EQ settings, and the position of its fader.

4

In mono channels (or in stereo channels where only the odd-numbered input is connected), you have the option of routing signal either to Aux sends 1, 2, 3, and 4 or to Aux sends 1, 2, 5, and 6 (depending upon the position of the Aux 5/6 switch—see #4 below). In stereo channels where both inputs are connected, the odd-numbered channel can be routed to Aux 1 and either Aux 3 or 5 (depending upon the position of the Aux 5/6 switch) and the even-numbered channel can be routed to Aux 2 and either Aux 4 or 6 (again, depending upon the position of the Aux 5/6 switch). For more information, see the "Auxiliary Sends and Returns" section in this manual.

5

7

8

9

4: Aux 5/6 switch - In mono channels (or in stereo channels where only the odd-numbered input is connected), the Aux 5/6 switch has the following function: When it is up, the "Aux 3/5" knob routes signal to Aux send 3 and the "Aux 4/6" knob routes signal to Aux send 4; when it is pressed in, the the "Aux 3/5" knob routes signal to Aux send 5 and and the "Aux 4/6" knob routes signal to Aux send 6.

10

In stereo channels where both inputs are connected, the Aux 5/6 switch has the following function: when the switch is up, the "Aux 3/5" knob routes signal from the odd-numbered channel to Aux 3 and the "Aux 4/6" knob routes signal from the even-numbered channel to Aux 4. When the Aux 5/6 switch is pressed in, the "Aux 3/5" knob routes signal from the odd-numbered channel to Aux 5 and the "Aux 4/6" knob routes signal from the even-numbered channel to Aux 6. For more information, see the "Auxiliary Sends and Returns" section in this manual.

5: Pan (white) - Provided in mono channels only. This knob allows you to place the input signal anywhere in the left-right stereo spectrum, while keeping the overall signal level constant. When the knob is placed at its center (detented) position, the signal is sent equally to both left and right

Guided Tour - Mono and Stereo Channels

busses (either busses 1 and 2 or busses 3 and 4, depending upon the setting of the Buss switch—see #7 below). When moved left of center, less signal is sent to the right buss (making the sound appear left of center) and when moved right of center, less signal is sent to the left buss (making the sound appear right of center). To route a signal to just one single buss, place the pan knob either fully counter-clockwise (the signal will be sent to just buss 1 or 3, depending upon the setting of the Buss switch) or fully clockwise (the signal will be sent to just buss 2 or 4, depending upon the setting of the Buss switch).

6: Balance (dark gray) - Provided in stereo channels only. When both inputs (odd-numbered and even-numbered) are connected to a stereo channel, the odd-numbered input signal is automatically panned hard left and the even-numbered input signal is automatically panned hard right. In this case, the “Balance” knob controls the relative levels of the paired input signals. When the knob is placed at its center (detented) position, both signals are at equal strength. When moved left of center, the odd-numbered channel remains at the same strength but the even-numbered channel is attenuated; when the knob is moved right of center, the even-numbered channel remains at the same strength but the odd-numbered channel is attenuated. When placed fully counter-clockwise, only the odd-numbered channel is heard (panned hard left); when placed fully clockwise, only the even-numbered channel is heard (panned hard right).

In stereo channels where only the odd-numbered input is connected, the Balance knob functions the same as a mono channel Pan control; see above for details. For more information, see the “Pan/Balance” section in this manual.

7: Buss switch - When up, the signal from the channel is routed to busses 1 and 2. When pressed in, the signal from the channel is routed to busses 3 and 4. Both pairs of busses terminate at the main mix output, with busses 1 and 3 normalled to the left output and busses 2 and 4 normalled to the right output. The final output level is determined by the Main Mix knob; see below. For more information, see the “Bussing, Submixing, and Channel Muting” section in this manual.

8: Solo switch - When pressed in, the channel is soloed in either PFL (Pre Fade Listen) or IPS (In Place Solo) mode, depending upon the setting of the Solo switch in the MPL 2242 main section. Refer to the “PFL and IPS” section in this manual for more information.

9: Peak LED (red) - This warning light indicates an overload situation. It lights whenever a channel’s signal is 5 db short of clipping. To stop it from lighting (and eliminate the accompanying sonic distortion), turn down the channel’s Input Trim knob (see above) or reduce the amount of equalization boost. See the “Setting the Correct Gain Structure” and “Equalization” sections in this manual for more information.

10: Channel fader (gray with a blue line) - In mono channels (or in stereo channels where only the odd-numbered input is connected), this linear slider determines the final signal level being sent to the main busses as well as affecting the levels being sent to Aux sends 2 - 6 (all of which are post-fader; Aux 1 is always pre-fader). In stereo channels, the fader controls the final level of both the odd-numbered and even-numbered inputs (the relative levels of the two can be adjusted with the Balance knob, as described above). In practice, you will use channel faders to continuously adjust the levels of the various signals being blended together by the MPL 2242. The “0” (detented) position of the fader indicates unity gain (no level attenuation or boost). Moving the fader below this position (towards the “∞” db position) causes the signal to be attenuated (at the very bottom, it is attenuated infinitely—in other words, there is no sound). Moving it above the “0” position (towards the “+15” position) causes the signal to be boosted by as much as 15 db.

For best signal-to-noise ratio, all faders carrying signal should generally be kept at or near the 0 level. Faders that are unused should be kept all the way down at their “∞” (minimum) level. See the “Setting the Correct Gain Structure” section in this manual for more information.

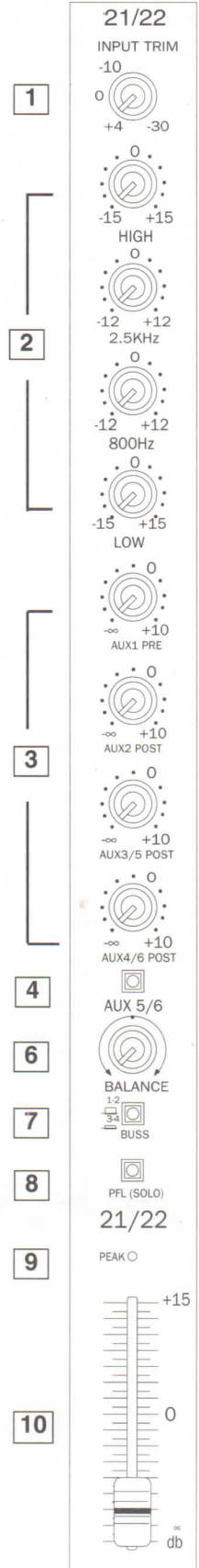

Guided Tour - Main Section

MPL 2242

2 CHANNEL 4 BUSS MIXER

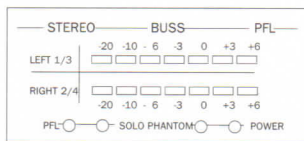

3

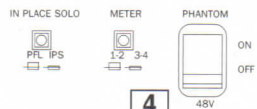

1
2

5

1: Meter - This seven-segment bar meter normally shows the continuous output level of either busses 1 and 2 or busses 3 and 4, depending upon the setting of the Meter switch (see #4 below). However, if a PFL (Solo) switch is pressed, the meter instead shows the PFL or IPS level (see the "PFL and IPS" section in this manual for more information). For optimum signal-to-noise ratio, try to adjust all levels so that program material is usually at or around 0 VU, with occasional but not steady excursions to the red +3 or +6 segments. See the "Setting the Correct Gain Structure" section in this manual for more information.

2: Meter LEDs - These show the status of various conditions within the MPL 2242. The rightmost LED (labeled "Power") lights steadily red when the MPL 2242 is powered on. The second from right LED (labeled "Phantom") lights steadily green when Phantom power is being supplied to all 10 mic inputs (see #5 below). The leftmost LED (labeled "PFL") lights steadily green when the MPL 2242 is in PFL mode (as determined by the main PFL/IPS mode switch—see #3 below) and flashes when one or more channel PFL (Solo) switches are pressed or when the Aux PFL switch is pressed (see #8 below). The second from left LED (labeled "Solo") lights steadily red when the MPL 2242 is in IPS mode (as determined by the main PFL/IPS mode switch—see #3 below) and flashes when one or more channel Solo switches are pressed.

3: PFL/IPS mode switch - This determines whether the MPL 2242 is in PFL mode (switch up) or IPS mode (switch pressed in). The corresponding meter LED lights steadily to give you a visual indication of the selected mode. For more information, see the "PFL And IPS" section in this manual.

4: Meter switch - This determines whether the seven-segment bar meter displays the continuous output level of busses 1 and 2 or busses 3 and 4. If one or more channels are soloed (by pressing the PFL (Solo) switch), the meter will instead display the level of the soloed channel(s).

5: Phantom switch - When this switch is turned on, the MPL 2242 delivers 48 volts of phantom power to pins 2 and 3 of all XLR microphone connectors (channels 1 - 10). **WARNING: Only turn this on or off with the MPL 2242 powered down. Before turning phantom power on, be sure to disconnect all non-microphone signal sources (such as direct injection boxes) from the XLR mic jacks. Although phantom power will generally have no adverse affect on connected dynamic microphones, it should be used only when one or more condenser microphones are connected to the MPL 2242. Refer to the owners manual of your microphone to determine whether or not it requires 48 volts phantom power—we cannot assume responsibility if you damage a mic by incorrectly applying MPL 2242 phantom power. If you're not sure that one or more connected mics require 48 volts phantom power, leave this switch OFF.**

6: Stereo Auxiliary Return Level (green) - These knobs determine the input level of signal arriving via the MPL 2242's four stereo Auxiliary returns. Each return is at unity gain (no boost or attenuation) when set to the 0 position. The input signal is boosted when the trim is turned to the right of 0 and attenuated when turned to the left of 0. For information on how to properly set these, see the sections in this manual entitled "Setting the Correct Gain Structure" and "Auxiliary Sends and Returns."

7: Stereo Auxiliary Return Balance (dark gray) - These knobs determine the relative levels of the left and right input signals connected to each of the MPL 2242's four stereo Auxiliary returns. When the knob is placed at its center (detented) position, both left and right input signals for that Aux return are at

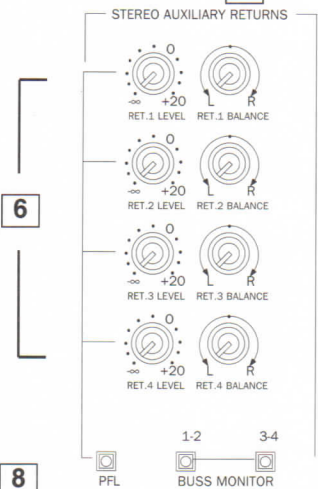

6

7

8

9

10

12

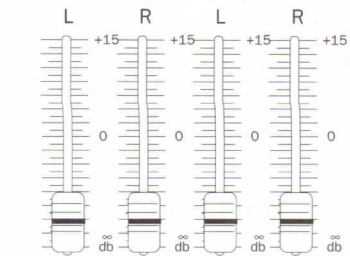

13

Guided Tour - Main Section

equal strength. When moved left of center, the left input signal remains at the same strength but the right input signal is attenuated; when the knob is moved right of center, the right input signal remains at the same strength but the left input signal is attenuated. When placed fully counter-clockwise, only the left input signal is heard (panned hard left); when placed fully clockwise, only the right input signal is heard (panned hard right). These “radical” positions are useful when you are using a stereo Aux return as two mono returns—see the “Auxiliary Sends and Returns” section in this manual for more information. When only the left input of an Aux return is connected, its Balance knob functions as a constant level Pan control, allowing you to continuously place the incoming signal anywhere in the left-right stereo field.

8: Auxiliary PFL switch - The function of this switch depends upon the setting of the PFL/IPS mode switch, as described above. When the PFL/IPS mode switch is up (that is, when the MPL 2242 is in PFL mode), pressing the Auxiliary Return PFL switch has no effect on the main mix output or on any Aux sends, but all stereo Aux returns are soloed (pre-level control) in the headphones. When this is occurring, the PFL LED in the meter section will flash, just as it does when any channel is soloed in PFL mode. Auxiliary PFL is useful for trouble-shooting, when you want to make sure that an external device is connected and is delivering signal to an MPL 2242 Aux return.

When the PFL/IPS mode switch is pressed in (that is, when the MPL 2242 is in IPS mode), pressing the Auxiliary PFL switch mutes all Aux sends except Aux 1 and, at the same time, solos all stereo Aux returns (post-level and post-balance control) in both the main mix and in the headphones. When this is occurring, the IPS LED in the meter section will flash. This allows you to hear the contribution of the auxiliary return signals to the overall mix. For more information, see the “Auxiliary Sends and Returns” section in this manual.

9: Phones Monitor switches - These two switches determine which buss signals are routed to the headphone jack. If the left switch is on, the signal from busses 1 and 2 (panned hard left and right) are routed to the headphone jack. If the right switch is on, the signal from busses 3 and 4 (panned hard left and right) are routed to the headphone jack. If both switches are on, the signal from all four busses are routed to the headphone jack (with busses 1 and 3 panned hard left and busses 2 and 4 panned hard right). In addition, the signals from any soloed channels are automatically routed to the headphone jack (interrupting the buss signals and substituting them with the PFL or IPS signals), as are the signals from the Aux returns if the Aux PFL switch is pressed (note that, since the Aux returns are not routed to any of the four busses, this is the only way that the headphones can receive signal connected to the Aux returns). When one or more channels are soloed (in either PFL or IPS mode), its signal is heard in the headphones in place of the selected buss output(s).

10: Main Mix (green) - This knob determines the final output signal level. Signals from both pairs of busses and all Aux returns are routed here just before leaving the MPL 2242 via its left and right Main Mix output jacks. You can think of this as being the “master fader”—and we made this knob extra big so you won’t miss it even under low-light performance conditions. For more information, see the “Setting The Correct Gain Structure” section in this manual.

11: Headphone Level (black) - This knob sets the level of the signal sent to the headphone jack, as determined by the Phones Monitor switches (see above).
WARNING: To avoid possible damage to connected headphones (or, worse yet, to your ears!), always turn this all the way off (to the fully counterclockwise “0”

Guided Tour - Jackfield

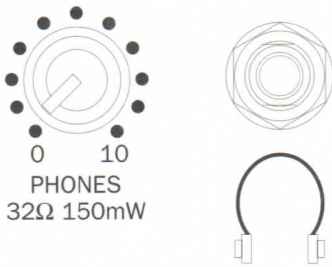

Headphone level control and headphone jack

position) before plugging in a pair of headphones—then raise the level slowly while listening. The Headphone Level has no effect on the final mix output level.

12: Headphone jack - Connect any standard stereo headphones to this jack (via a standard 1/4" TRS plug) for monitoring of any buss or soloed signals (see above). The built-in MPL 2242 headphone preamp delivers 150 mw at 30 ohms.

13: Buss faders (white) - These linear sliders determine the relative level of each of the four main busses just prior to being sent to the Main Mix control. The "0" (detented) position of each fader indicates unity gain (no level boost or attenuation). Moving the fader below this position (towards the "∞" db position) causes the signal to be attenuated (at the very bottom, it is attenuated infinitely—in other words, there is no sound). Moving it above this position (towards the "+15" position) causes the signal to be boosted by as much as 15 db.

For best signal-to-noise ratio, all buss faders being used should generally be kept at or near the 0 level. See the "Setting The Correct Gain Structure" section in this manual for more information.

Finally, let's take a look at the MPL 2242 jackfield, where all the input and output connectors are located (note: See the four Applications notes at the rear of this manual for specific suggestions as to interconnections between the MPL 2242 and other equipment).

1: Power switch - As you may have guessed, this is what you use to turn the MPL 2242 on and off. To avoid potential damage to your speakers, turn the mixer on before you turn on any connected power amps—and turn it off after the power amps are turned off.

2: Main Mix out (L,R) - These are the MPL 2242's main outputs; busses 1 and 3 (along with signals connected to the left side of the four stereo Auxiliary returns) terminate at the left output and busses 2 and 4 (along with signals connected to the right side of the four stereo Auxiliary returns) terminate at the right output. You'll usually use these to connect the MPL 2242 to a power amp and speakers. The Main Mix out jacks are electronically balanced, so you should use balanced three-conductor cabling and plugs wherever possible (unbalanced two-conductor plugs can also be inserted into these outputs, but you'll get better signal quality and less outside noise and hum if you use balanced lines). See the "Connecting the MPL 2242" section in this manual for more information.

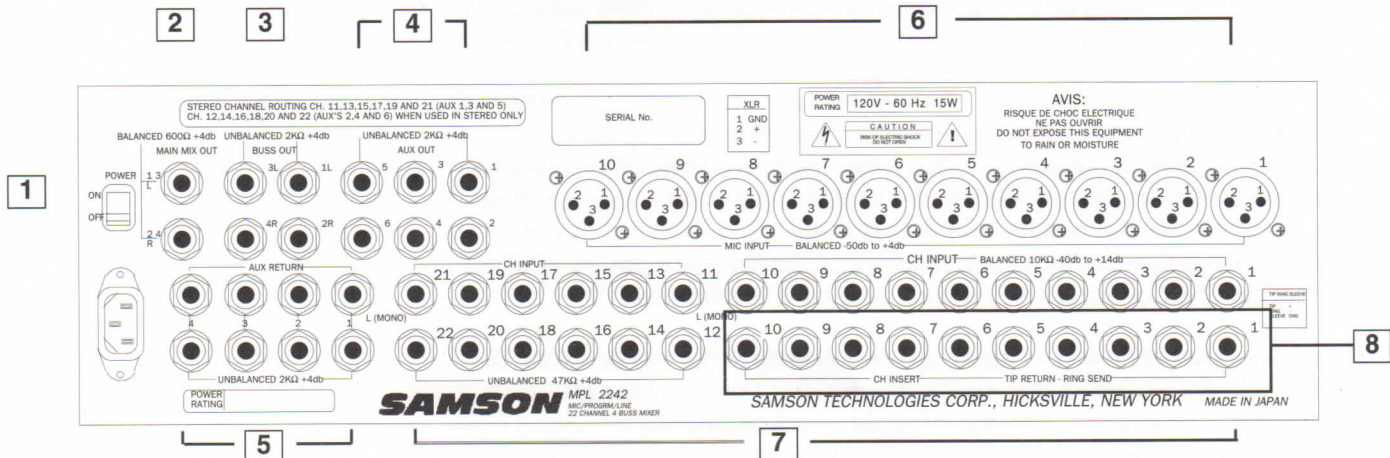

3: Buss out (1-L, 3-L, 2-R, 4-R) - These unbalanced outputs allow you to route signal from each of the four discrete busses to external devices such as a multi-track tape recorder. The signal is post-buss fader but pre-Main Mix control. Note that signals connected to the MPL 2242's stereo Aux returns are not routed to any of these four buss outputs. See the "Bussing, Submixing, and Channel Muting" section in this manual for more information.

4: Aux out (1 - 6) - These unbalanced outputs allow you to route signal from each of the six discrete Auxiliary sends to external devices such as effects processors. Note that the output from Auxiliary 1 is always pre-fader and pre-EQ, while the output from the other five Auxiliary sends are always post-fader and post-EQ.

5: Aux return (1 - 4, L - R) - These unbalanced inputs allow you to route signal from external devices such as effects processors to the Stereo Auxiliary return section of the MPL 2242. Stereo devices should be connected to both the left and right inputs of each Aux return; mono devices should be connected to the left input. When only the left input is connected, the front panel Aux return Balance knob functions as a Pan control; see the "Pan/Balance" section in this manual. You can use the Aux return section to input signal from up to four stereo sources or eight mono sources. Note that signals connected to the MPL 2242's stereo Aux returns are not routed to any of the four buss outputs. See the "Auxiliary Sends and Returns" section in this manual for more information.

6: Mic inputs (1 - 10) - Use these to connect microphones to any of the MPL 2242's ten mono channels (channels 1 - 10). These are intended to accept signal from low-level, low-impedance mics but can also be used for signal from other sources (such as direct injection boxes) if the Input Trim control is turned down. **WARNING:** Do not turn Phantom power on if signal sources other than microphones are connected to any of these inputs. Also, do not connect a channel's microphone input if you already have something connected to its line input; each channel is designed to accept only one source or the other.

7: Channel inputs (1 - 22) - Use these to connect line-level sources such as synthesizers, drum machines, CD players, tape decks, or effects processors to any of the MPL 2242's twenty-two input channels. Channels 1 - 10 (which are mono) provide electronically balanced input jacks while channels 11 - 22 provide unbalanced input jacks. When connecting only one monophonic signal to a stereo channel, use the odd-numbered input; the MPL 2242 will then treat that channel as if it is a mono channel and the signal can then be panned (using the Balance control) and can access four auxiliary sends (see the "Pan/Balance" and "Auxiliary Sends And Returns" sections in this manual for more information). The "Connecting The MPL 2242" section in this manual provides more information on how best to use channel inputs. **WARNING:** Do not connect a channel's line input if you already have something connected to its microphone input; each channel is designed to accept only one source or the other. Note also that each mic input has 10 dB more gain than a mono line channel.

8: Channel inserts (1 - 10) - Use these to insert an external effects processor (such as outboard equalizers, compressor/limiters or noise gates) into any of the MPL 2242's ten mono channels in an "effects loop" configuration. These jacks accept 1/4" TRS plugs, with the ring carrying the send signal and the tip carrying the return signal. Normally, this will be connected to a Y-cable; see the "Connecting The MPL 2242" section in this manual for more information and a wiring diagram.

Connecting The MPL 2242

The actual connections you'll make to and from the MPL 2242 will vary according to the environment you use it in and the particular equipment you have. In the "MPL 2242 Applications" sections at the rear of this manual, you'll find some suggested setups. Here are a few basic rules concerning MPL 2242 connections that will apply in pretty much all situations:

- In general, it's best to make all connections with the MPL 2242 and any connected power amplifiers turned off. If you must make connections with the power on, make sure that the Main Mix level is completely down (turn the knob fully counterclockwise). Whenever powering down, turn the Main Mix level completely down and turn off the main power amps *first*. Wait a few seconds for their power supplies to discharge and then turn off all connected equipment, turning the MPL 2242 off *last*.
- Try to use balanced connectors and cabling wherever possible. These kind of connections do a better job of rejecting extraneous noise and hum and generally provide a cleaner signal. Although the MPL 2242 will accept unbalanced connectors throughout, it specifically provides balanced inputs for all ten mono channel inputs (channels 1 - 10) and for its main mix outputs. The wiring diagram below shows how 1/4" TRS (Tip/Ring/Sleeve) connectors should be wired for use with these inputs and outputs*:



Unbalanced cables use standard 1/4" phone connectors, wired as follows:



- Make one connection at a time and then monitor the incoming signal. If you hear a distinct hum or buzz, you may have a grounding problem with that particular device. See the section in this manual entitled "Grounding Techniques" for information on how to avoid grounding problems.
- NEVER connect a microphone and line level input to the same channel simultaneously—use one or the other. You can have some channels connected to microphones and others to line level signals (for example, you might want to plug mics into channels 1 - 6 and line level signals into channels 7 - 10)—just don't have both kinds of inputs connected to the *same* channel. The diagram below shows how your mic connectors should be wired*:



* You'll also find this information silkscreened on the MPL 2242 rear panel.

Connecting The MPL 2242

- For single-fader control over a pair of matched signals (i.e. the left-right outputs of a stereo effects processor, keyboard, drum machine, tone generator, CD player, or tape recorder), use the MPL 2242's stereo input channels (11/12, 13/14, 15/16, 17/18, 19/20, and 21/22). The Balance control in these channels will allow you to adjust the relative levels of the two inputs, and you can also equalize the stereo signal, with the same EQ settings applied to both inputs.

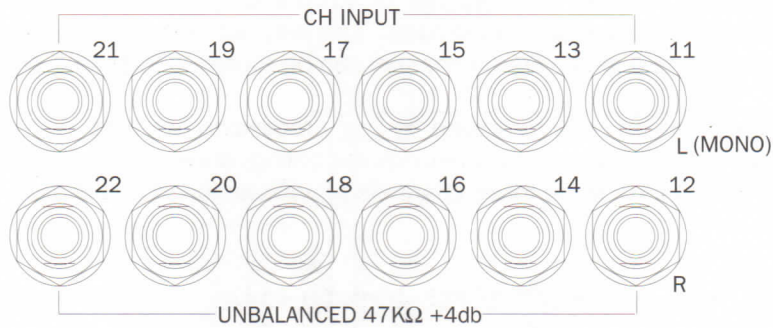

- There are four more "hidden" (or at least not so obvious) stereo inputs to the MPL 2242; these are the Auxiliary returns. Use these whenever you want to bring in a stereo signal that will not need to be equalized or routed to one of the four output busses (signals connected to the Aux returns are sent directly to the main mix output). Also bear in mind that the four stereo Auxiliary returns can also be used as eight monophonic returns (with the Aux Balance controls giving you the ability to adjust the relative levels of the left/right inputs). If you're using the MPL 2242 in live performance to drive a mono PA system, you may not need to take the stereo returns from outboard effects processors.

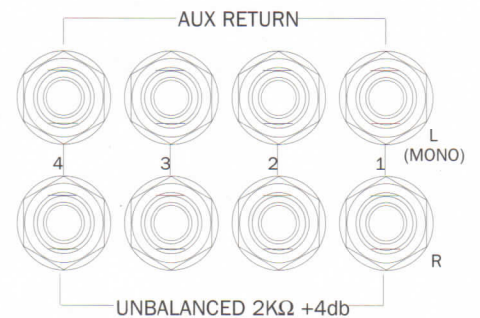

- The line inputs to the MPL 2242's stereo channels are considerably "hotter" than the line inputs to mono channels, although both kinds of channels provide the same amount of attenuation. Devices that output extremely high line-level signals should therefore be connected to mono channel line inputs (channels 1 - 10).
- When connecting only one monophonic signal to a stereo channel, always use the odd-numbered input. When only the odd-numbered input is connected in a stereo channel, the MPL 2242 treats that channel as if it is a mono channel and the signal can then be panned (using the Balance control) and can access four auxiliary sends. See the "Pan/Balance" and "Auxiliary Sends And Returns" sections in this manual for more information.

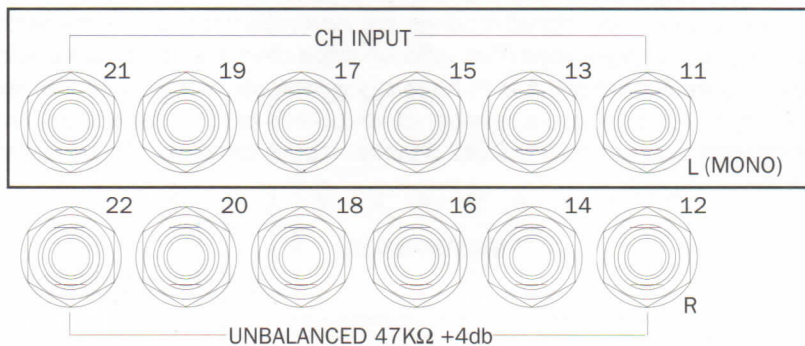

Use odd-numbered inputs when connecting monophonic signal to a stereo channel.

Connecting The MPL 2242

- Because Aux 1 is the only one of the six auxiliary sends that is pre-fader, you should use it only where a pre-fade mix is required. For example, in a recording situation, Aux 1 is optimum for headphone cueing or for driving a secondary monitor (such as a studio room monitor). In live performance, Aux 1 can be used to route signal to an *onstage monitor* system so that the signal the performers hear is independent of the house mix.
- If you're using a multieffects processor that has two (or four) discrete inputs, you should use the "matched pair" of Aux 3 and 4 to send signal (plus Aux 5 and 6, if the device has four inputs). This way, left and right signals connected to a single stereo channel can be routed to the same device.
- Signals that are likely to require "in-line" processing (such as compression/limiting or expansion/noise gating) should be connected to channels 1 - 10, since these channels provide an insert connection.

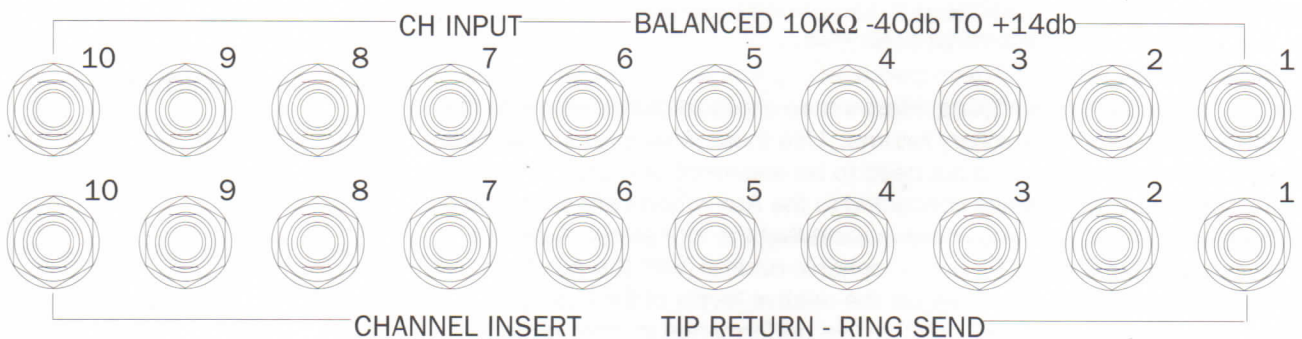

Insert cables (sometimes called "Y-cables") should terminate in standard 1/4" TRS jacks (tip to return and ring to send), wired as follows:

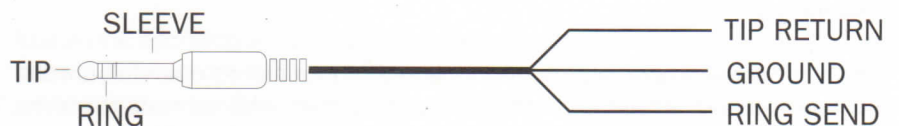

- If you're using a patch bay with the MPL 2242, plan the layout of the bay so that most every-day signal routings are *normalised* (that is, permanently connected) or *half-normalised* (that is, connected unless a patch cable is inserted). The traditional setup is to have signal outputs over inputs. For example, you might want to have a number of keyboards or tone generators half-normalised to specific MPL 2242 channel inputs, as shown in the illustration on the next page:

Connecting The MPL 2242

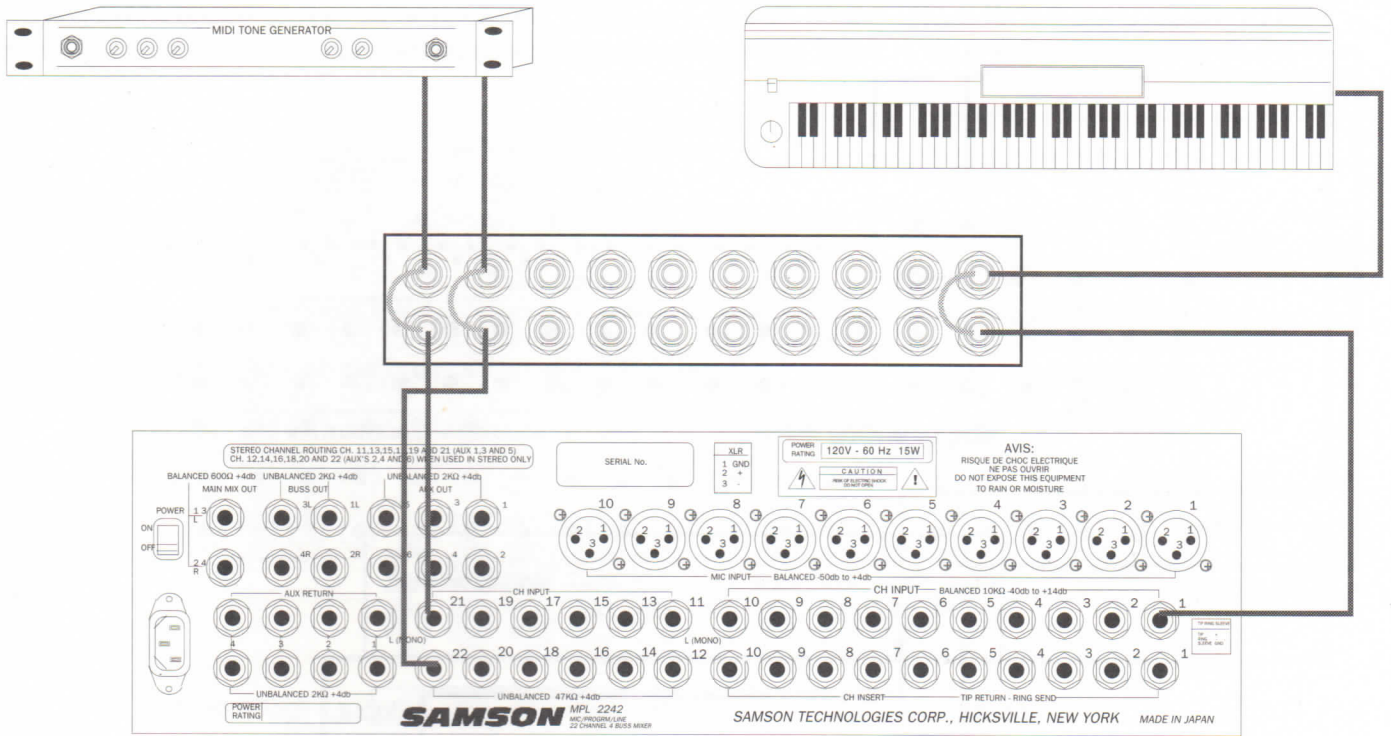

Or you might want to have a DAT player connected to the Aux 2 return, and a tape deck connected to Aux 3:

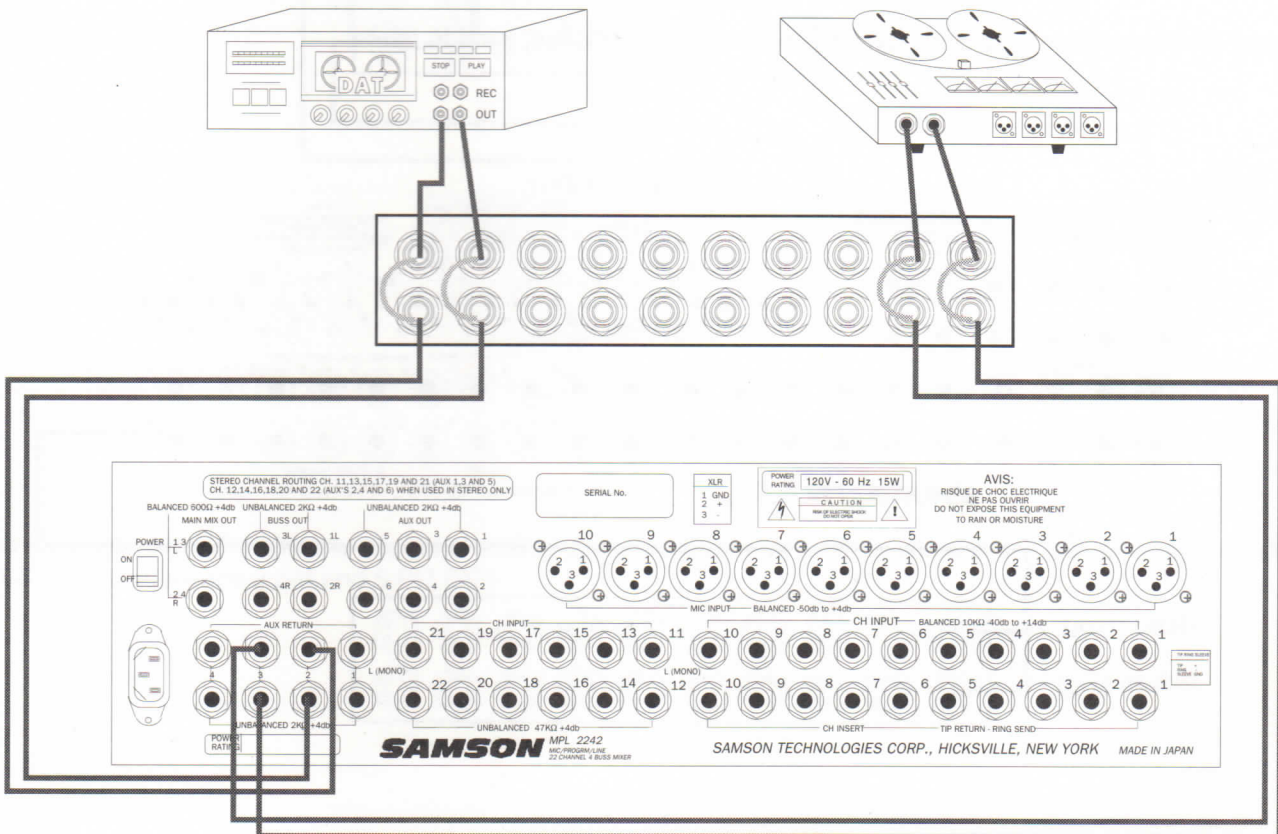

Connecting The MPL 2242

You might want to have particular Aux sends routed to specific outboard signal processors:

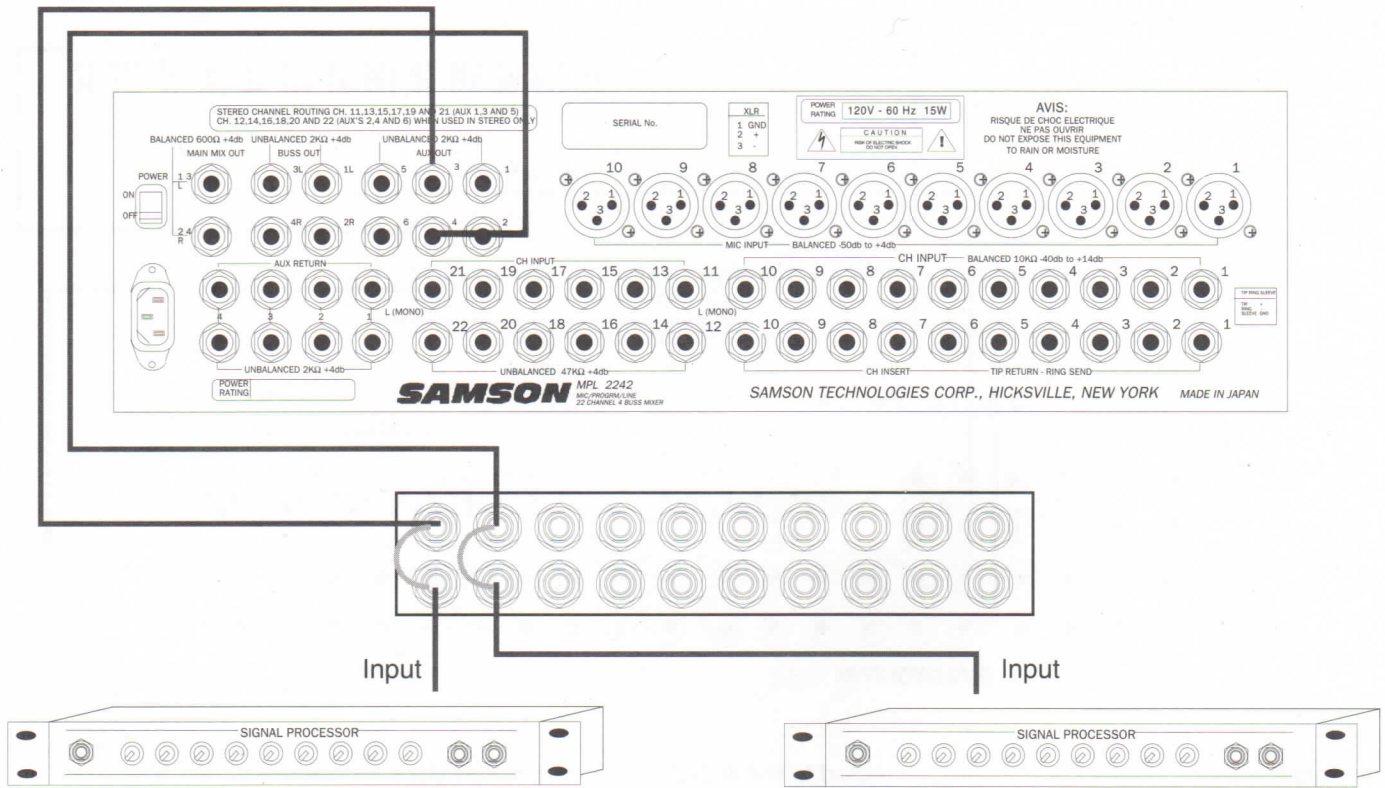

If you bring channel inserts to the patch bay, they must be half-normalled, send to return:

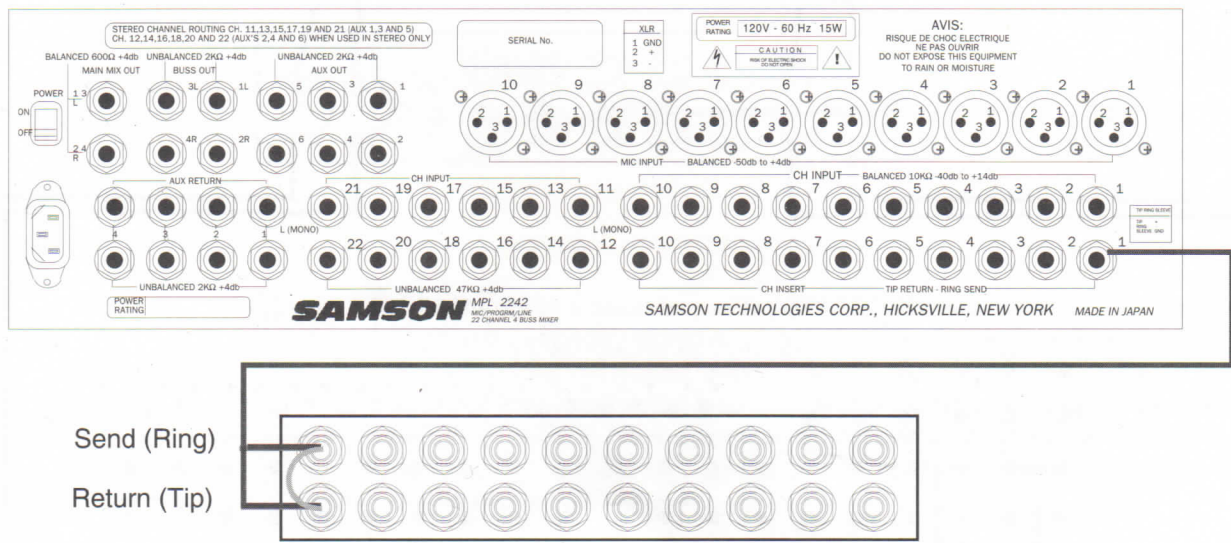

Connecting The MPL 2242

Then, to insert a device such as a compressor to a particular channel, all you have to do is insert a patch cord from the channel insert send to the compressor input, and from the compressor output to the channel insert return:

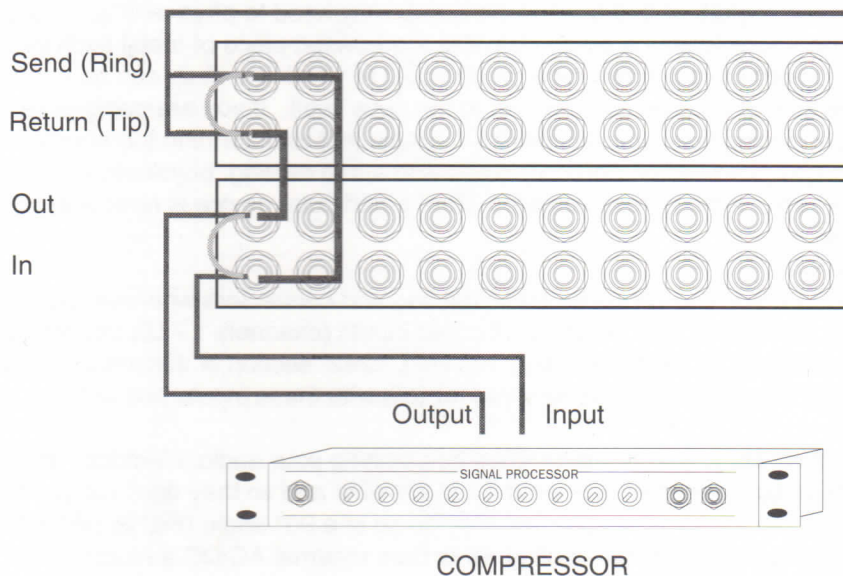
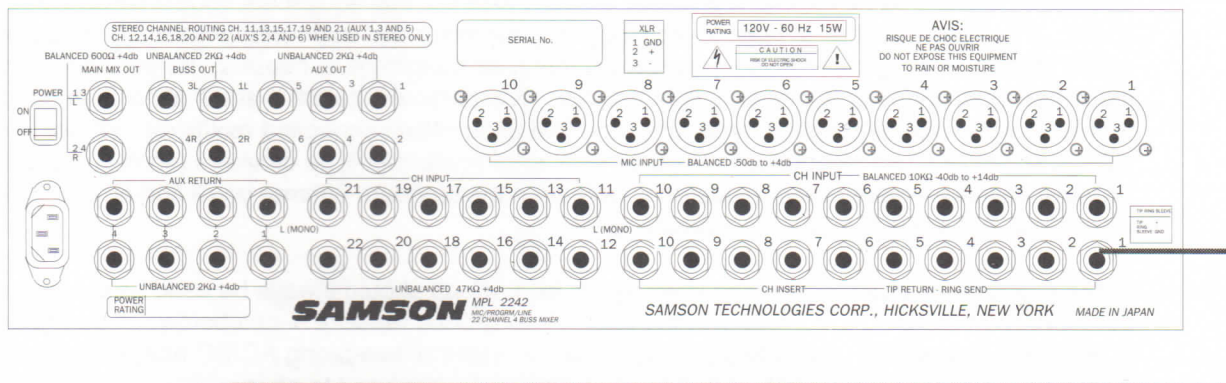

If you encounter difficulty with any aspect of setting up or using your MPL 2242, you can call Samson Technical Support (516-932-1062) between 9 AM and 5 PM EST.

Grounding Techniques

Hum and buzz are the biggest enemies you face when interconnecting a large number of different pieces of equipment to a central audio mixer. This is because each piece of equipment may operate at a marginally different voltage (this difference is called *potential*) and, when two devices at slightly different potential are physically connected with audio cabling, the end result can be nasty, extraneous noise (mind you, connecting two devices at *very* different potential can result in a major electrical shock!).

However, there are several steps you can take to avoid grounding problems. First, assuming you have an isolated electrical circuit that can handle the electrical demands of your mixer and all connected audio equipment (these needs will usually be modest), you should always plug your mixer and all connected equipment into the same circuit. If possible, nothing else but this equipment should be connected to that circuit. If you can't do this, at least avoid plugging your mixer and audio equipment into the same circuit that is already powering things like heavy machinery, air conditioners, heaters, refrigerators, washing machines, neon signs or fluorescent light fixtures. One particular culprit that will almost certainly create problems is the standard light dimmer (the kind that uses silicon controlled rectifiers). Where low-level lighting is desired, use incandescent fixtures with autotransformer-type dimmers (sometimes called *Variacs*) instead—these cost considerably more than the standard dimmer you'll find at your local hardware store, but are well worth the extra expense.

Three-prong plugs (such as the one used by the MPL 2242) should always be used as is; don't use adapters to lift the ground (unless you're using a "star ground network"—see below). If you hear hum or buzz from a device that uses a two-prong plug (or an external two-prong AC/DC adapter), you can try reversing the plug in the socket. If that doesn't work, you may need to physically ground that device's chassis by connecting a wire (called a *strap*) from it to a grounded piece of metal such as rack ears. Some pieces of equipment have a screw-type ground post to which the strap can be connected; if not, you can attach some kind of metallic binding post to the case itself. If you are using rack-mounted audio devices and are experiencing hum or buzz, there's a simple test to determine the source of the problem: while keeping all devices powered on and connected with audio cabling, physically remove each device, one by one, from the rack. If the hum disappears when a particular device is removed, you'll know that that device is the culprit.

We also recommend that you use balanced audio cabling and connectors wherever possible. The MPL 2242 provides balanced inputs for all ten mono channel inputs (channels 1 - 10) and for its main mix outputs. The wiring diagram in the "Connecting The MPL 2242" section of this manual shows how 1/4" TRS (Tip/Ring/Sleeve) connectors should be wired for use with these inputs and outputs.

In addition, you can minimize possible interference by planning your audio, electrical, and computer cable runs so that they are as far apart from one another as possible and so they don't run parallel to one another. If they have to cross, try to ensure that they do so at a 90° angle (that is, perpendicular to one another). In particular, try to keep audio cabling away from external AC/DC adapters

If you're using the MPL 2242 in a fixed location such as a recording studio, you may want to invest the time and money into creating a *star ground network*. This is by far the best technique for avoiding grounding problems. It involves using a formidable ground source such as a cold water pipe or a copper spike driven into the earth. A thick grounding cable is connected to that source and is then brought to a central distribution point; from there, individual cables are connected to each piece of equipment. This setup also requires that you lift the ground plug of all three-prong AC connectors, so there is the possibility of danger if it is done incorrectly. We strongly recommend that you contract with a qualified professional to carry out this or any kind of electrical work.

Another, less common problem you may encounter is that of *oscillation* (a ringing tone), which, apart from being annoying, is potentially dangerous to your speakers. This is generally caused either by poor outside wiring or by returning a signal out of phase (most commonly from an outboard signal processor). If audible oscillation occurs, try isolating each input signal (by muting all other inputs or by using the PFL/IPS functions). If one signal alone is causing the problem, you should be able to eliminate the oscillation by reversing that signal's phase (many signal processors have a switch that allows you to do this).

MPL 2242 Signal Flow

A good understanding of signal flow is vital to understanding how to use any mixer. Here's a diagram that shows how signal flows through the MPL 2242:

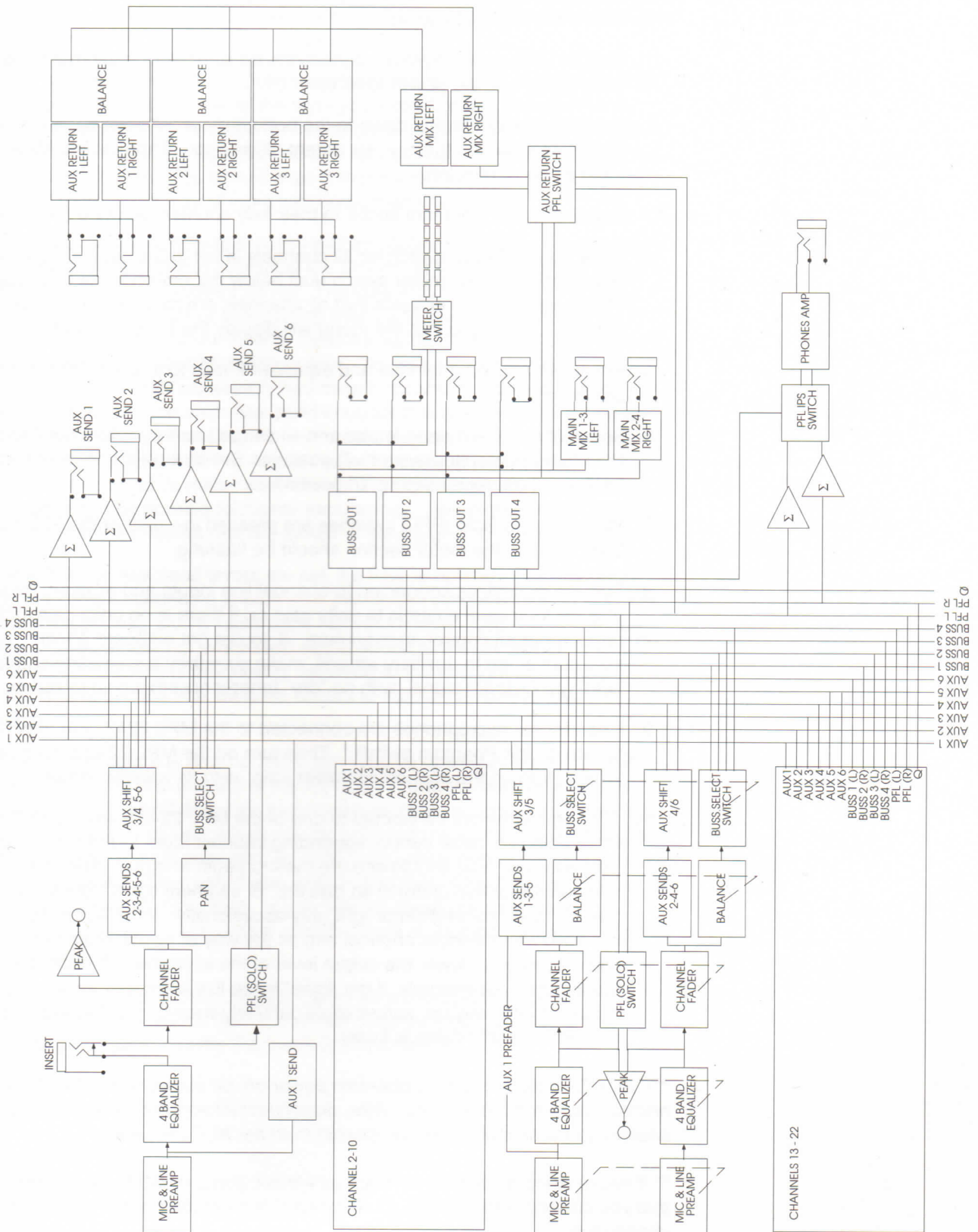

Setting the Correct Gain Structure

The key to getting the best performance from the MPL 2242 is to establish the correct gain structure. This is a simple procedure that ensures optimum input and output levels so that no unnecessary noise (caused by too low a signal) or overload distortion (caused by too high a signal) is created. Here's a step-by-step description of how to do so:

1. Start by making all physical connections between your equipment and the MPL 2242, with the power to all units off.
2. Bring all channel faders down to the bottom-most "∞" position, and bring all four buss faders to their center detent "0" position. Then set the Main Mix knob to its "0" position.
3. Set all channel input trim knobs to their fully counterclockwise (+4) position.
4. Make sure the buss switch for all channels is set to the out (1-2) position. Also make sure the meter switch (just below the meter) is set to its out (1-2) position. This ensures that all channels are routing signal solely to busses 1 and 2 and that the meter will display the buss 1-2 output.
5. Set all channel pan/balance and equalizer knobs to their center detent "0" positions.
6. Set all channel aux send knobs and all stereo auxiliary return level knobs to their fully counterclockwise ("∞") position. Set all auxiliary return balance knobs to their center detent "0" position.
7. Make sure no Solo (PFL) switches are pressed in—neither the PFL nor Solo LEDs in the meter section should be flashing.
8. Turn on all devices connected to channel line inputs and auxiliary returns and set their level controls to unity gain or, if there is no unity gain indicated on their output control, to maximum. If you've got outboard effects processors connected to auxiliary returns, make sure they are sending completely "wet" (processed) signal, with no "dry" (unprocessed) signal mixed in.
9. If condenser microphones are connected to the MPL 2242, you may need to turn on the Phantom switch.* Then turn on the MPL 2242's main power. Finally, turn on the connected power amp, *with its volume completely off*.
10. Play an instrument connected to one of the MPL 2242's line inputs** and, while doing so, raise the corresponding channel fader to the center detent ("0") position. You should see the meters begin to move. Adjust the input trim control for that channel so that the "0" segment lights frequently and the "+3" and "+6" segments light only occasionally. If the signal seems too hot even with the input channel trim all the way at its minimum (+4) setting, you may need to lower the output level of the instrument, though this will rarely occur. Conversely, if the signal is too low even with the input channel trim all the way up, something's definitely wrong: in all likelihood, the connecting audio cable is faulty.

* **CAUTION:** Before turning phantom power on, be sure to verify that the connected mic(s) require 48 volts. Also, disconnect all non-microphone signal sources (such as direct injection boxes) from the XLR mic jacks.

** If you're using an instrument such as electric guitar or bass, we recommend that you connect it to the MPL 2242 with a direct injection box to ensure correct impedance.

Setting the Correct Gain Structure

11. Once you've set the optimum level in step (10) above, continue playing the instrument and slowly raise the volume of the power amplifier until you get the level you want to hear.
12. Repeat step (10) above for each instrument connected to the MPL 2242's mono and stereo channel line inputs.
13. The procedure for setting optimum microphone levels is virtually identical; sing or speak into the mic at the level you expect to use in performance while slowly raising the fader for that channel to its "0" center detent position. Then adjust the input trim control for that channel while watching the MPL 2242 meter. You should expect that microphone inputs will require rather more in the way of input trim boost than line inputs.
14. Because outboard effects processors can sometimes be quite noisy, it's particularly important to maximize the amount of signal being sent to them via the MPL 2242 auxiliary sends. The idea is to drive these devices as hot as possible (short of overloading them) and then to use the corresponding Auxiliary return level to carefully adjust the amount of processed signal returning to the Main Mix output. To set optimum aux send levels, use a channel that has already had its gain structure adjusted in step (10) or (13) above. Turn each Aux send knob for that channel to its "0" (unity gain) position and then play the instrument (or sing into the microphone) connected to that channel. Adjust the input levels of each outboard effects processor so that its meter shows incoming signal normally in the 0 vu range (with just occasional higher excursions). Remember that you need to press in the channel Aux 5/6 switch to send signal to Aux sends 5 and 6.
15. Now that the Aux send levels are set, it's time to optimize the Aux return levels. While continuing to play your instrument (or continuing to sing into the microphone), slowly raise each Aux return level control until you hear the desired amount of processed signal added to the dry signal. If you have different effects processors returning to the left/right inputs of a stereo Aux return, use the Aux Balance control to adjust the relative levels of each.
16. The gain structure is now correctly set—you've optimized the level of all signals coming into and out of the MPL 2242, and the end result will be minimum noise and distortion and maximum clean sound. You'll now find that the majority of your mixes can be accomplished with most channel and buss faders working near their 0 (unity gain) center detent position and that channel peak LEDs rarely if ever light (remember, if they do light, it means that something is distorting!). If you need to make adjustments to the overall level, you can either alter the level of your power amp or use the Main Mix knob.

Note that, although this procedure only called for working with busses 1 and 2, if you press in the meter switch and all channel buss switches, you'll find that busses 3 and 4 register exactly the same optimum levels.

Bussing, Submixing, and Channel Muting

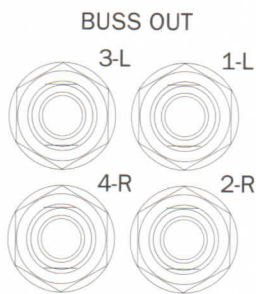

As we've seen, the MPL 2242 uses a system of four *busses* to route signal to the Main Mix output. A "buss" is simply a pathway through which a signal can be routed. In the MPL 2242, busses 1 and 3 terminate at the left side of the Main Mix output and busses 2 and 4 terminate at the right side of the Main Mix output. This four-buss system (which eventually mixes down to a single stereo output) gives you a great deal of flexibility in terms of signal flow.

For example, you may want to connect the MPL 2242 to a four-track cassette or open-reel tape recorder. One good way to do this is to route each of the four individual buss outputs to a tape input, and to bring each of the four tape outputs back to individual channels. With this setup, to record onto track 1, route one or more instrument or microphone channels to buss 1 (via the channel Buss switch and Pan control); to record onto track 3, route them to buss 3, etc. See the Application section at the conclusion of this manual for more information on using the MPL 2242 as a recording mixer.

Another important plus is that you can use each buss to set up a *submix* within your overall mix. For example, let's suppose that you're using the MPL 2242 to do live sound and you have eight microphones on the drum kit—separate mics for the bass and snare drums as well as for the hi-hat, another mic for each of three tom-toms, and an overhead pair for picking up cymbals. To get all this signal into the MPL 2242, you're going to have to use eight mono channels. During a sound check, you'll usually start with the drums, working to get the blend of the eight different drum mics just right. After that's done, the next step is typically to start bringing in the other instruments. During the gig, however, you may need to raise or lower the overall level of the drums, but you surely won't want to upset the blend you so carefully set up. This won't be easy to do if you have to move eight faders at once! The solution is to use the bussing system provided by the MPL 2242—route the eight drum channels to one buss and all other instruments to another (if you're working in stereo, route the eight drum channels to one pair of busses and all other instruments to the other pair). Now you can adjust the overall level of the entire drum mix by moving just one (or two) buss faders!

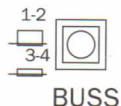

You can also use the MPL 2242 buss switches to *mute* particular channels (that is, remove them temporarily from the overall mix without having to change their fader position). To do this, keep buss faders 3 and 4 down at their " ∞ " position (no signal) and use busses 1 and 2 for your overall mix. Then, to mute a signal, all you have to do is press that channel's Buss switch; the signal will be rerouted to busses 3 and 4 (which are off) and will be removed from the mix you hear. To restore the signal (that is, *unmute* it), all you have to do is press that channel's Buss switch again—since its fader hasn't been moved, the sound will come back at the same level as before.

The final Main Mix output of the MPL 2242 is stereo—that is, there are two discrete output jacks, labeled “left” and “right,” which will normally be routed to two discrete speakers.* Because of this, you will usually be working with a stereo field that ranges from hard left to hard right. The Pan control in each mono channel (and the Balance control in each stereo channel, when only the odd-numbered input is connected) allows you to place each individual sound at any point within this left-right field, while keeping the overall level constant.



You can use stereo panning creatively in a variety of ways: For example, you might want to have guitars coming from one speaker and keyboards from another, or you might use panning to “spread” the signal from a piano miked with two microphones—one over the bass notes (panned left) and the other over the treble notes (panned right). By turning a Pan knob while a signal is present, the sound appears to move in space (a process known as *dynamic panning*)—this can be particularly effective when applied to sound effects.

In live performance, you may want to resist the temptation to pan anything completely hard left or right, since some members of the audience not seated in the center of the venue may miss some signal altogether. In these circumstances, you’re best to use modest panning, with signals routed no further than the 9 o’clock and 3 o’clock positions.

The Pan control also allows you to send mono signals to just one specific buss output. For example, if a channel Buss switch is up and its Pan control is set to hard left, the signal will go to buss 1 only; if the Pan control is set hard right, the signal will go to buss 2 only. With the Buss switch in, the signal will go to buss 3 only (Pan hard left) or buss 4 only (Pan hard right).

In stereo channels where both inputs are connected, the odd-numbered input signal is automatically panned hard left and the even-numbered input signal is automatically panned hard right. The Balance knob in these channels controls the *relative levels* of the paired input signals. When the knob is placed at its center (detented) position, both the odd-numbered and even-numbered channels are at equal strength. When moved left of center, the signal of the odd-numbered channel remains the same but the signal of the even-numbered channel is attenuated; when the knob is moved right of center, the the signal of the even-numbered channel remains the same but the signal of the odd-numbered channel is attenuated. When placed fully counter-clockwise, only the odd-numbered channel is heard; when placed fully clockwise, only the even-numbered channel is heard.



* You can, of course, also use the MPL 2242 monophonically—simply route the same signal to both the left and right outputs.

Pan/Balance

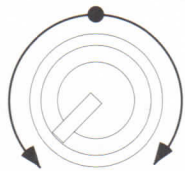

RET. 1 BALANCE

In the stereo Auxiliary return section, the Balance control works in a similar fashion.

In Aux returns where both inputs are connected, the left signal is automatically panned hard left and the right signal is automatically panned hard right. The Balance knob controls the relative levels of the paired input signals. When the knob is placed at its center (detented) position, both the left and right signals are at equal strength. When moved left of center, the left input signal remains the same but the right input signal is attenuated; when the knob is moved right of center, the right input signal remains the same but the left input signal is attenuated. When placed fully counter-clockwise, only the left input is heard (panned hard left); when placed fully clockwise, only the right input is heard (panned hard right).

If you connect different monophonic devices (such as effects processors) to both the left and right inputs of an Aux return, you can use the Aux Balance control to blend the relative contribution of each. If you turn the Balance knob fully counterclockwise, you'll hear only the device connected to the left Aux input; if you turn it fully clockwise, you'll hear only the device connected to the right Aux input. For more information, see the "Auxiliary Sends and Returns" section below.

One of the most exciting aspects of using a mixer such as the MPL 2242 is having the ability to shape a sound, using a process called *equalization*. But there are few areas of sound engineering more misunderstood than equalization, and, just as good EQ can really help a sound, bad EQ can really hurt it, so read on...

Every naturally occurring sound consists of a broad range of pitches, or *frequencies*, combined together in a unique way. This blend is what gives every sound its distinctive tonal color. The EQ section in a mixer allows you to alter a sound by boosting or attenuating specific frequency areas. In the MPL 2242, you are provided with independent four-band equalization controls for each of the 22 input channels. Each EQ knob is labeled with its center frequency (12 kHz, 2.5 kHz, 800 Hz, and 80 Hz) and with the maximum amount of cut or boost provided (± 15 db in the case of the highest and lowest frequencies and ± 12 db in the case of the two mid frequencies).

These particular frequency areas are provided by the MPL 2242 because they have maximum impact on musical signals—that's why they are sometimes known as "sweet spots." When an EQ knob is in its center detented position ("0"), it is having no effect. When it is moved right of center, the particular frequency area is being boosted; when it is moved left of center, the frequency area is being attenuated. The high and low EQ controls employ what is known as a *shelving curve* (where frequencies either above *or* below the specified area are affected) while the two mid frequency controls employ what is known as a *bell curve* (where frequencies both above *and* below the specified area are affected). The equalization controls in stereo channels affect both the odd-numbered and even-numbered input signals simultaneously.

In many instances, the best way to approach equalization is to think in terms of which frequency areas you need to attenuate, as opposed to which ones you need to boost (boosting a frequency area also has the effect of boosting the overall signal; too much EQ boost can actually cause overload—with the accompanying Peak LED warning—even if the Input Trim control is set correctly!). Be aware of the phenomenon of *masking*, where loud sounds in one frequency range obscure softer sounds in the same range; by cutting EQ "notches" in a loud signal, you can actually make room for a softer one to shine through. Get in the habit of *normalizing* the EQ settings of all channels (that is, turn all EQ controls to their center "0" position) when you've finished a session, so that you aren't applying EQ to a signal unknowingly. And try not to think of EQ as a miracle worker—no amount of equalization can put a singer in tune or remove the distortion from an overloaded input signal! The key is to get the signal right in the first place, by using correct gain structure and mic placement.

Although the specific EQ you will apply to a signal is very much a matter of personal taste, here are a few general suggestions: Boosting the low frequency of instruments such as bass drums or bass guitar will add warmth and make the sound "fatter"; conversely, you may want to attenuate the low frequency component of instruments such as cymbals, high-hats, and shakers so as to "thin" them out. The mid-range controls are particularly effective for vocals—attenuating the low-mid control can give a vocal performance more of an "FM-radio" feel and boosting the high-mid control can help a vocal cut through dense instrumentation. Be careful not to boost high frequencies too much or you risk adding hiss to the signal, though just a touch can help add "shimmer" to an acoustic guitar, ride cymbal, or high-hat. Finally, because both the high and low EQ settings are shelving controls, you can use them to reduce hiss (by attenuating high frequencies) or rumble (by attenuating low frequencies).

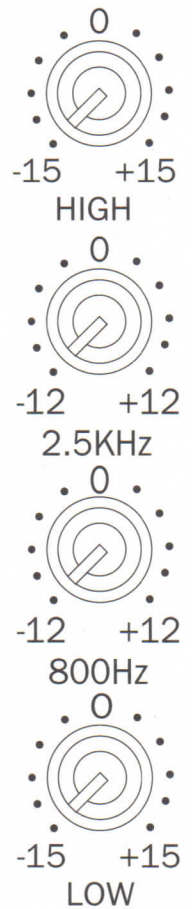

Auxiliary Sends and Returns

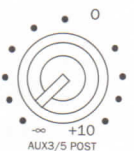
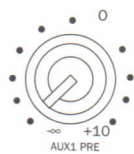

The MPL 2242's system of Auxiliary sends allow you to combine the signal from multiple channels and send the resulting mix to external devices such as effects processors. There are six discrete Auxiliary sends and, at any given time, each channel can access four of them.

In mono channels (or in stereo channels where only the odd-numbered input is connected), you are given the option of routing signal either to Aux sends 1, 2, 3, and 4 (if the Aux 5/6 switch is up) or to Aux sends 1, 2, 5, and 6 (if the Aux 5/6 switch is pressed in). In stereo channels where both inputs are connected, the odd-numbered channel can be routed to Aux sends 1 and 3 (if the Aux 5/6 switch is up) or Aux sends 1 and 5 (if the Aux 5/6 switch is pressed in). The even-numbered channel can be routed to Aux sends 2 and 4 (if the Aux 5/6 switch is up) or Aux sends 2 and 6 (if the Aux 5/6 switch is pressed in).*

When an Aux send knob is at the "0" position, the signal is routed with unity gain (that is, no boost or attenuation). As it is turned clockwise from the 0 position, the signal is boosted; as it is turned counterclockwise from the 0 position, it is attenuated. Auxiliary send 1 is always *pre-fade*; that is, the level of the signal sent through this knob is determined solely by the input trim and is unaffected by the channel fader or EQ settings; for this reason, it is optimum for applications like headphone cuing or sending a feed to onstage monitors—both situations where you want the performer's mix to be independent of the main mix. You can also use Aux 1 to route signal to a reverb processor in order to create a distancing kind of effect where the "wet" reverb signal remains constant even as the "dry" source signal fades away. All other auxiliary sends are *post-fade*; that is, the level of the signals is determined by the input trim, the EQ settings, and the position of the channel fader. Here, raising or lowering the input level of the channel will affect the send level as well.

The MPL 2242 also provides four stereo Auxiliary returns. These allow you to return signal from outboard devices, either in stereo pairs or monophonically (many popular effects processors provide a single mono input but two stereo outputs). In practice, you'll probably want to use the Auxiliary returns to bring in signal from connected effects processors. If the effects processors have stereo outputs, they should be connected to both the left and right Auxiliary return inputs so that their stereo integrity is retained. If they have mono outputs, you can route them to either the left or right inputs and then use the Auxiliary return Balance control to adjust the relative level of each paired signal. In this way, you can actually connect up to eight monophonic devices to the MPL 2242's Aux return section.

Each of the stereo Auxiliary returns is somewhat similar to a stereo channel, except that a signal being brought into to a stereo channel can be equalized if necessary and optionally sent on to other outboard devices (via Aux sends or channel inserts). Also, signal brought into a stereo channel is always routed to either of the two buss pairs, while signals brought into to the MPL 2242's Auxiliary returns do not terminate at any of the four output busses (they terminate directly at the Main Mix output). The signal from the Aux returns can therefore be monitored over headphones only when the Auxiliary PFL switch is pressed in (with the MPL 2242 in either PFL or IPS mode) or when one or more channels are soloed with the MPL 2242 in IPS mode.

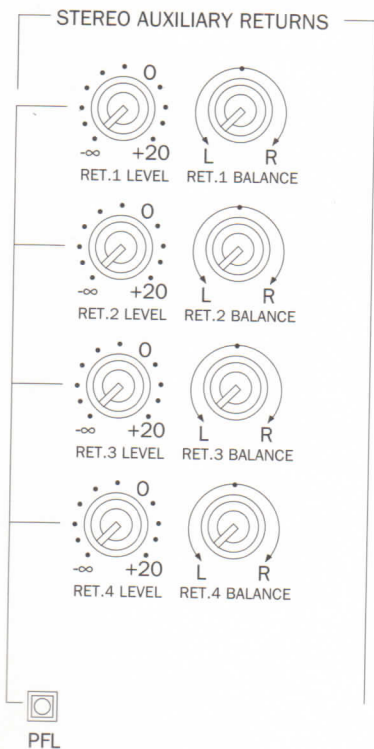

* You'll also find this information silkscreened on the MPL 2242 rear panel.

Channel Inserts

In addition to using Auxiliary sends and returns to access outboard devices, the MPL 2242 also provides *channel inserts* for the first ten input channels. These should be used when you want to affect just one channel's signal, as opposed to signal from several channels—most often, this will be for dynamic processing purposes (such as outboard equalization, compression/limiting, or noise gating). You can also use the channel insert sends as post-eq (but pre-fader) direct outputs, if you need to route a single monophonic signal to an external device such as a tape deck.

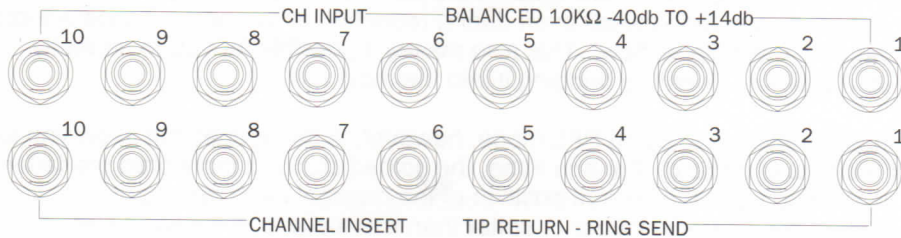

The channel insert jacks on the rear panel accept 1/4" TRS plugs, with the ring carrying the send signal and the tip carrying the return signal; this will normally be connected to a Y-cable (see the "Connecting The MPL 2242" section in this manual for a wiring diagram). This configuration is sometimes known as an "effects loop," since the signal is sent and returned over the same cable.

If nothing is plugged into the channel insert jacks, they have no effect—but if you connect them to a passive device like a patchbay, you'll need to normal or half-normal the send to the return. As shown in the "MPL 2242 Signal Flow" section of this manual, the insert signal is returned just before the channel fader. For this reason, you'll have to be careful to set the output of external devices connected this way to unity gain.

PFL and IPS

IN PLACE SOLO

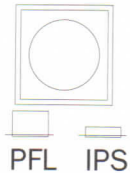

The MPL 2242 provides two options for soloing a input signals—*Pre Fade Listen (PFL)* and *In Place Solo (IPS)*. The Solo switch in the main section allows you to choose between them. Although they may at first glance appear similar, there are in fact several significant differences between the two modes.

The main function of PFL is to allow you to check that a signal is actually arriving at a particular input. When the MPL 2242 is in PFL mode and a channel PFL (Solo) switch is pressed, the pre-fader (but post-EQ) signal of that channel alone is routed to the headphone output and to the meters (both sets of meters show the input signal in mono—even if the channel being soloed is a stereo channel). The buss outputs and Main Mix outputs are not interrupted during a PFL solo, so you can press any Solo switch even during recording or live performance without affecting the main signal flow. This also makes it possible for you to correctly cue up a tape or CD before bringing it into the main mix.

The main drawback to using PFL mode, however, is that it does not allow you to hear a signal *in context*. For one thing, the soloed signal is monitored pre-fader, so, depending upon the current position of the channel fader and input trim, it may sound considerably louder or softer than it actually is in the Main Mix. Secondly, the soloed signal is always monitored monophonically—even if it's actually panned off to one side or is coming from a stereo channel. Finally, the PFL soloed signal appears without any outboard signal processing being applied via the Aux sends and returns (however, any signal processing being applied by a channel insert routing is heard).

For these reasons, you may in some circumstances prefer to use IPS mode, which provides true in-context soloing. When the MPL 2242 is in IPS mode and a channel PFL (Solo) switch is pressed, all other channels are muted, as are their Aux sends 2 - 6 (Aux send 1, being pre-fader, is not muted). The signal from the soloed channel alone—along with the signal from all four stereo Aux returns—is routed both to the Main Mix output and to the headphone output (IPS is *mix-destructive*—it will always interrupt the signal leaving the MPL 2242 from the Main Mix output). You'll hear the IPS soloed signal at its current level and pan position, along with its EQ settings and all effects being applied and returned via both the channel insert (if the soloed channel is a mono channel) and all Aux returns. The IPS soloed signal also appears at whichever buss outputs it is currently being routed to (as determined by the status of its Buss switch). If the IPS soloed channel is a stereo channel with both inputs connected, you'll hear both the odd-numbered and even-numbered inputs, panned hard left and right, and at the relative levels determined by that channel's Balance control.

The Aux returns can also be soloed (in either PFL or IPS mode) by pressing the Aux return Solo switch. The main function here is to allow you to determine that an outboard device is correctly connected to an Aux return and is delivering signal. If the MPL 2242 is in IPS mode, pressing the Aux return Solo switch will cause Aux sends 2 - 6 of all non-soloed channels to be muted.

LEDs in the meter section allow you to see at a glance which mode the MPL 2242 is in and whether or not a signal is currently being soloed. The leftmost LED (labeled "PFL") lights steadily green when the mixer is in PFL mode and flashes when one or more channel PFL (Solo) switches are pressed or when the Aux PFL switch is pressed. The second from left LED (labeled "Solo") lights steadily red when the mixer is in IPS mode and flashes when one or more channel Solo switches are pressed or when the Aux PFL switch is pressed. If you don't hear a sound from the MPL 2242 when everything else seems to be functioning correctly (i.e. mixer and power amps are turned on, connectors are plugged in, etc.), a likely reason might be that one or more of the channel PFL (Solo) switches (or the Aux return PFL switch) may be pressed in—so check the meter section before panicking!



PFL (SOLO)

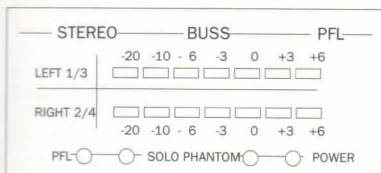

Applications

Here are four suggested applications for the MPL 2242; bear in mind that your particular circumstance may dictate changes in these suggested signal connections and routings.

Application 1 - Using the MPL 2242 as a main live mixer

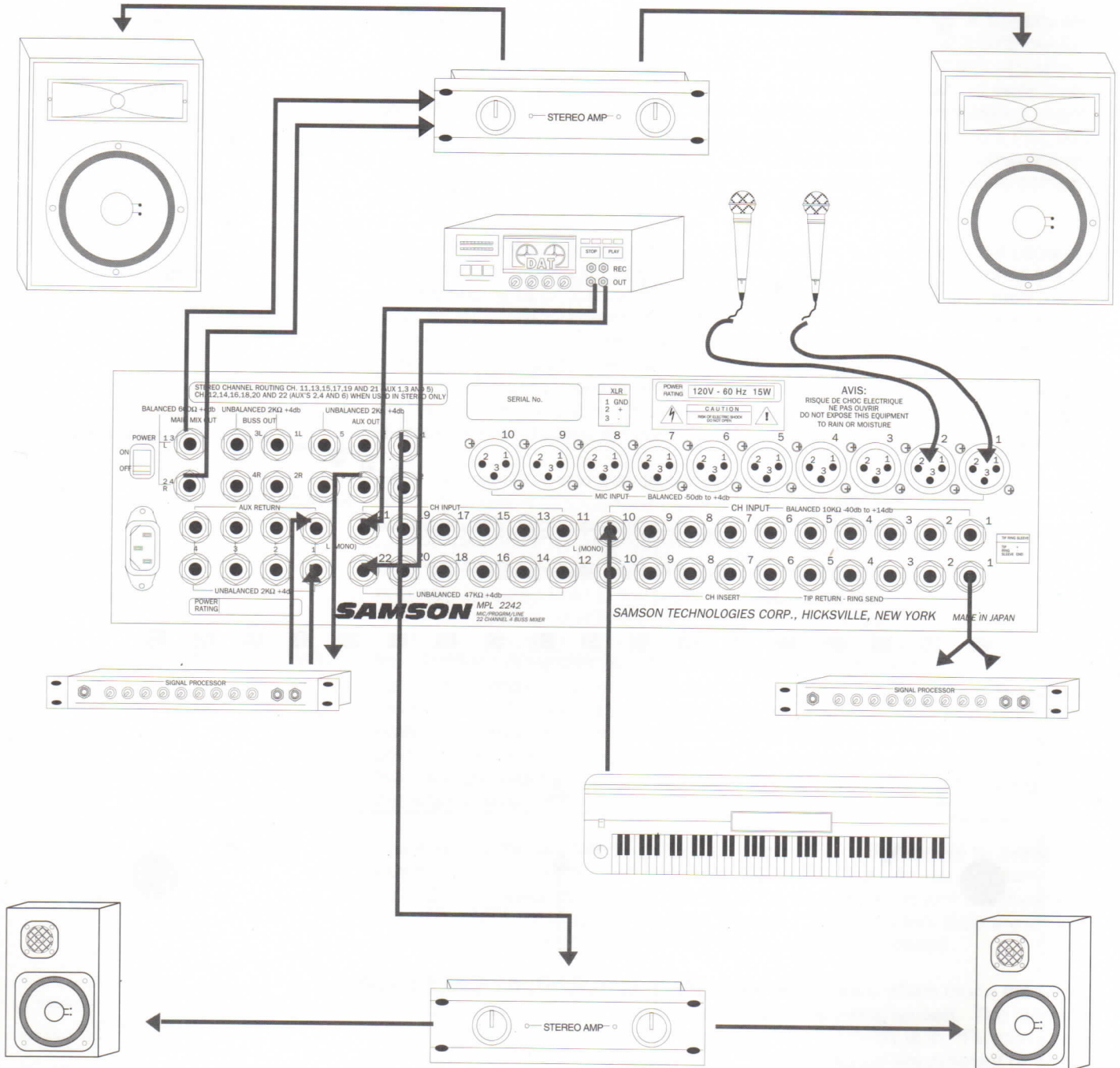

The main connections here involve routing the MPL 2242's Main Mix output to the input of a power amplifier, and, from there, to PA speakers. Microphones and monophonic line level signals requiring insert processing are connected to mono channel inputs and stereo line level signals are connected to stereo channel inputs. Signal processors are connected to Aux sends and returns and to channel inserts as required. A submix from Aux send 1 is connected to the input of a second power amplifier driving onstage monitor speakers so that performers can receive a monitor mix independent of the house mix.

Application 2 - Using the MPL 2242 as an onstage monitor mixer

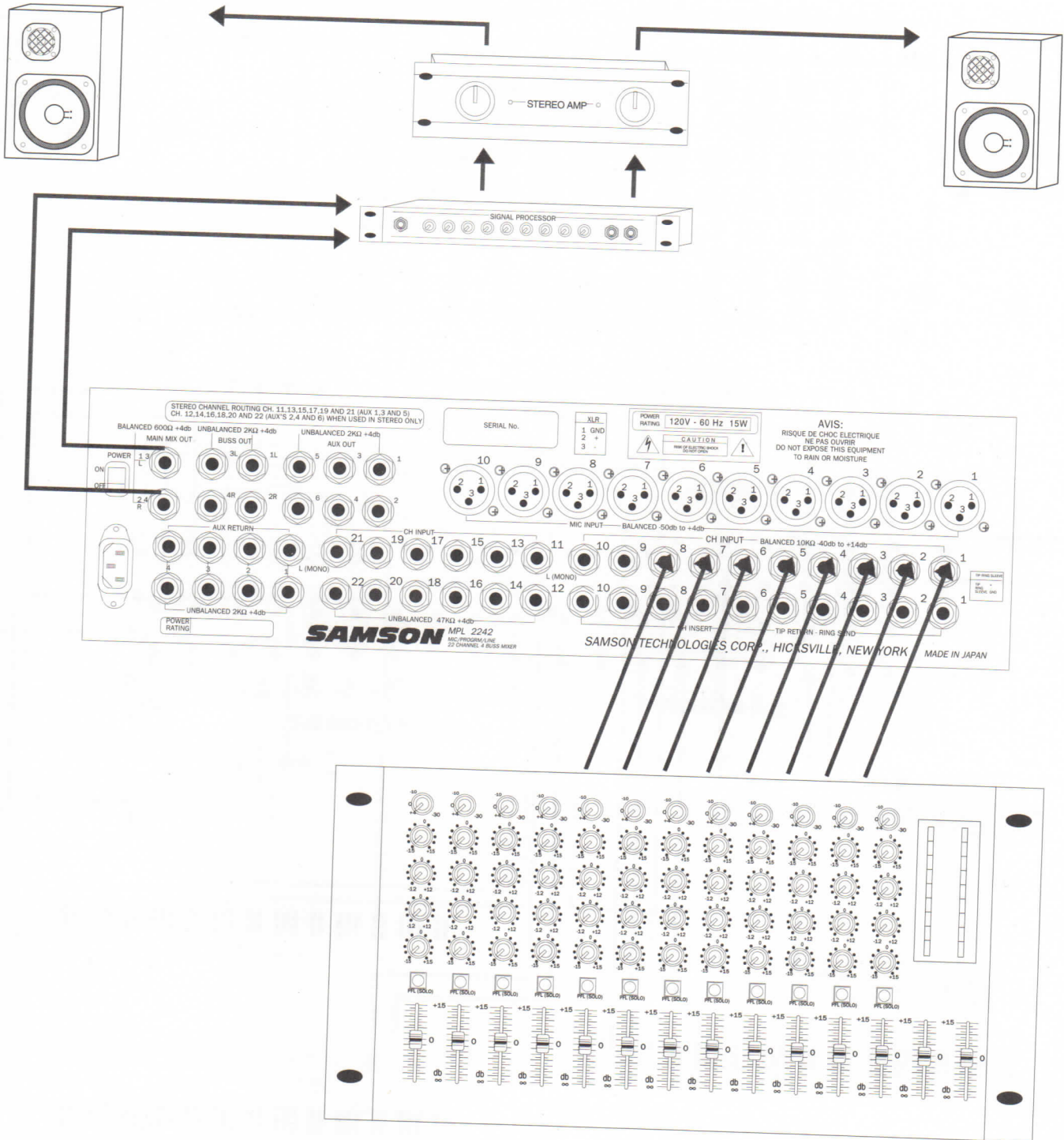

Here, the MPL 2242 is receiving monophonic signal into its line inputs from the direct channel outputs of a main live mixer. Its Main Mix output is connected to an outboard signal processor (typically an equalizer) prior to being routed to an amplifier and onstage monitors. This allows the overall mix to be adjusted in order to eliminate feedback and ringing problems.

Applications

Application 3 - Using the MPL 2242 as a keyboard submixer

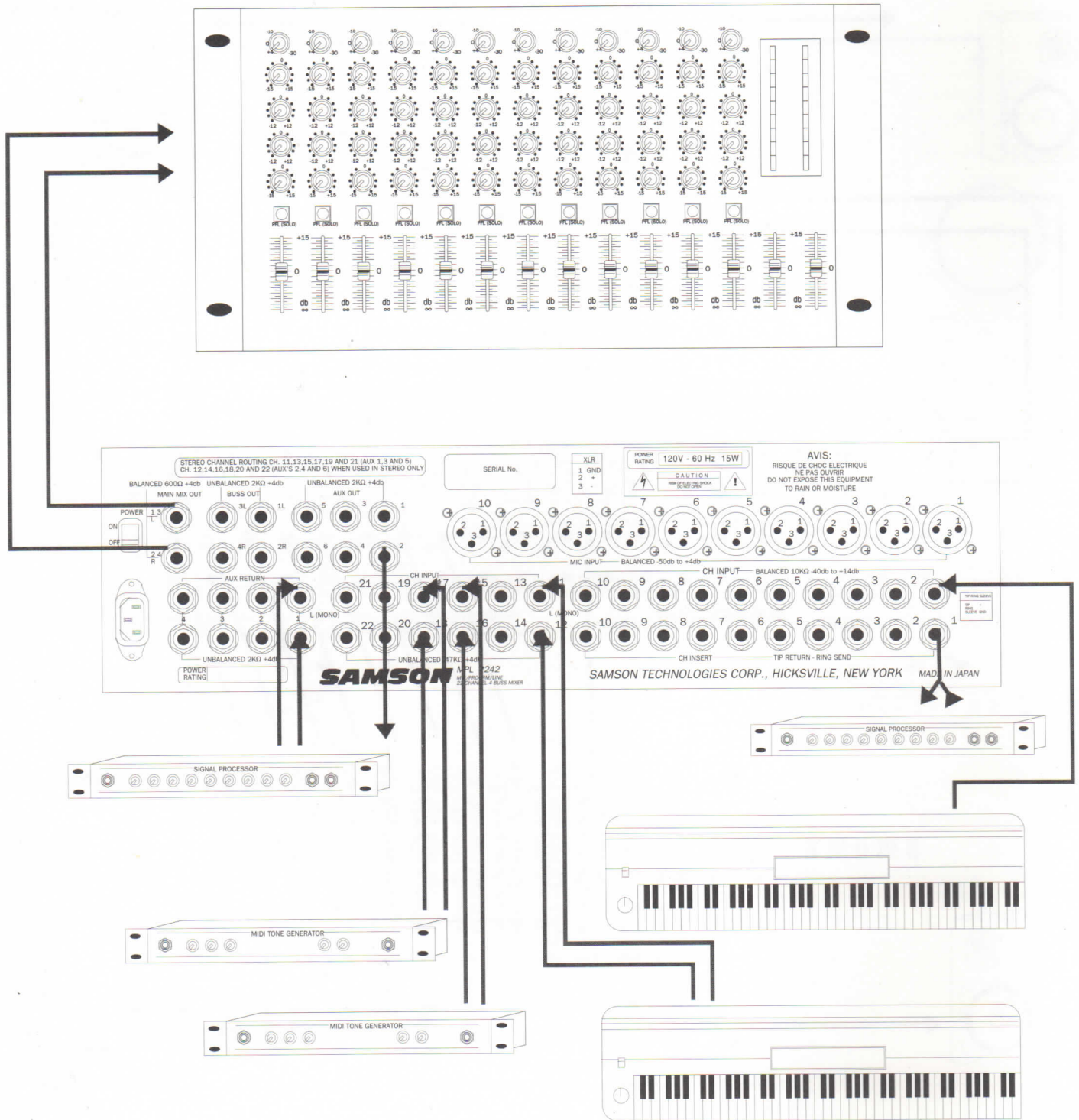

Here, various keyboards and MIDI tone generators are connected to the mono and stereo line inputs of the MPL 2242. Signal processors are connected to Aux sends and returns and to channel inserts as required. The Main Mix output can then be routed to a stereo input channel of a live performance or recording mixing console, with the performer having complete control over the blend of signals being provided to the sound engineer.

Application 4 - Using the MPL 2242 as a recording mixer

You'll find a description of this setup on the following page.

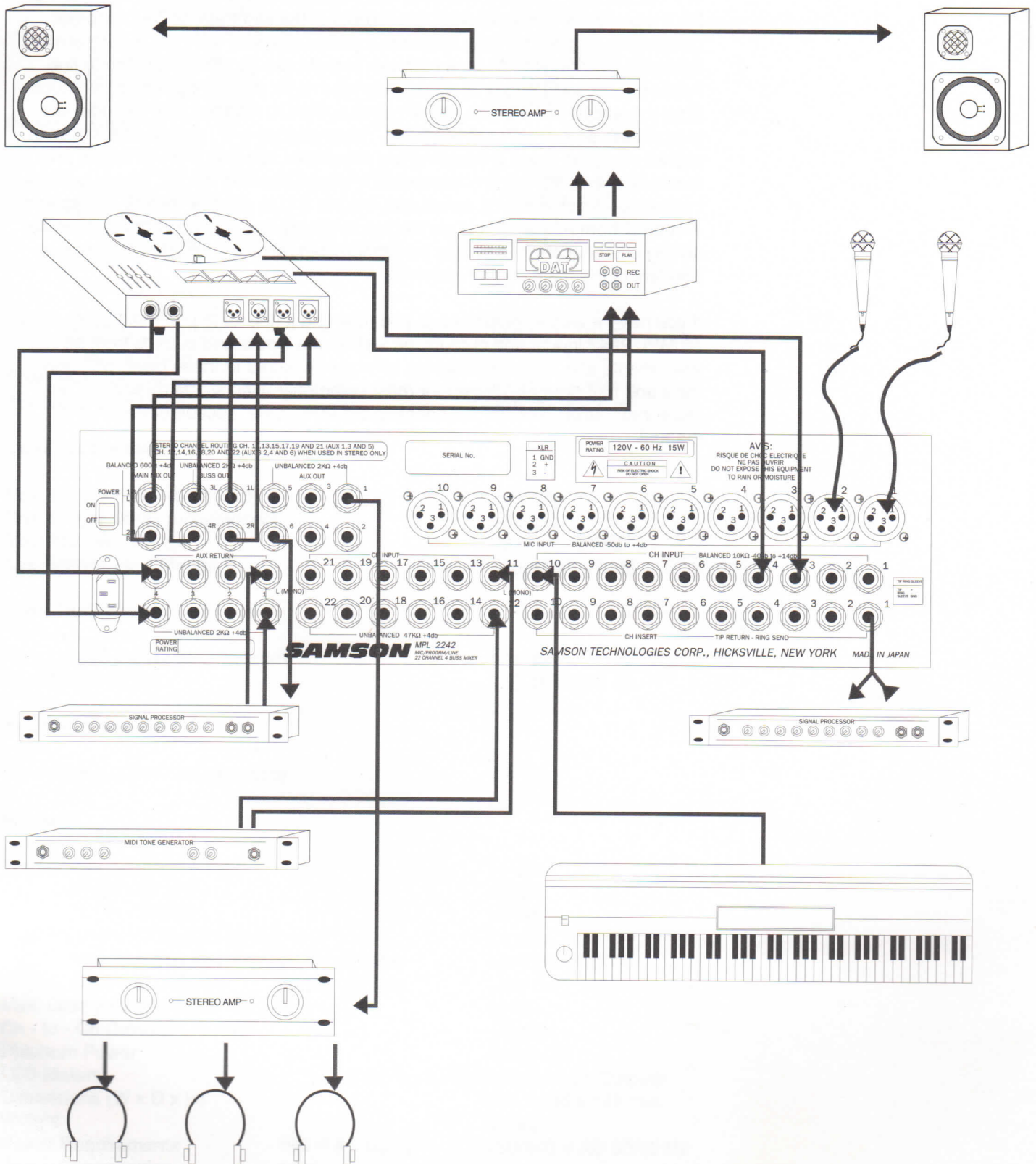

Applications

In the recording studio, you'll want to connect the MPL 2242's buss outputs to the inputs of a multitrack tape recorder (if you're using more than four tracks, you can use a patch bay or signal splitter to mult each of the four buss outputs to two or more tracks). Typically, the Main Mix outputs are connected to a two-track or DAT recorder for mixdown, with the outputs of the two-track or DAT recorder (monitoring incoming signal) routed to a power amplifier driving the control room speakers. The multitrack tape recorder outputs can be returned to mono line inputs for mixdown and/or to stereo Aux returns for monitoring during overdubs (again, you can use a patch bay or signal splitter to *mult* the tape recorder outputs to both sets of MPL 2242 inputs). Microphones and monophonic line level signals requiring insert processing are connected to mono channel inputs and stereo line level signals are connected to stereo channel inputs. Signal processors are connected to Aux sends and returns and to channel inserts as required. A submix from Aux send 1 is connected to the input of a second power amplifier driving cue headphones so that performers can receive a headphone mix independent of the main control room mix.

If you have a very involved setup, you may find it helpful to purchase patch bays. All MPL 2242 inputs and outputs, as well as the inputs and outputs from all instruments and signal processors, can be connected to these bays, with normals and half-normals utilized for most commonly-used signal routings. For more information, see the "Connecting the MPL 2242" section earlier in this manual.

Specifications

Channel Section:

Mic and Line Input (Channel 1 - 10)	
Mic E. I. N. (DIN Audio)	
150 Ω source	-128 dBu
Input shorted	-131 dBu
Trim Gain Range	0 dB to +54 dB
Max Input (Mic Input)	+18 dBu
Max Input (Ch. Input)	+28 dBu
Ch Input (Channel 11 - 22)	
Ch E. I. N (DIN Audio)	
Input shorted	-117 dBu
Trim Gain Range	0 dB to +34 dB
Max Input	+21 dBu
L. R. Crosstalk (1kHz)	-65 dB
Equalization	
High (shelving)	12 kHz \pm 15 dB
2.5 kHz (peaking)	2.5 kHz \pm 12 dB
800 Hz (peaking)	800 Hz \pm 12 dB
Low (shelving)	80 Hz \pm 15 dB
Channel Fader Range	+15 dB to -80 dB
Aux Send Gain Range	+10 dB to -75 dB

Main Mix Section:

Max. Output 600 Ω (balanced)	+25 dBu
Max. Output 600 Ω (unbalanced)	+20 dBu
Main Mix Gain Range	+6 dB to -80 dB
Aux Returns Gain Range	+20 dB to -70 dB

Buss Out Section:

Max. Output 2.2 k Ω (unbalanced)	+21 dBu
Buss Fader Range	+15 dB to -80 dB

Aux Send Section:

Max. Output 2.2 k Ω (unbalanced)	+21 dBu
---	---------

General:

Frequency Response (Unity)	+4 dBu
10 Hz - 20 kHz	\pm 1 dB
10 Hz - 50 kHz	\pm 3 dB
Total Harmonic Distortion (Unity)	+4 dBu
Main Mix Out (600 Ω) 20 Hz - 20 kHz	Less than 0.03%
Buss Out (2.2 k Ω) 20 Hz - 20 kHz	Less than 0.015%
Max. Gain (Mic in to Main Mix out)	90 dB
Ch - to - Ch Crosstalk (1 kHz)	-85 dB
Phantom Power	+48 V DC
LED Meters	0 VU = +4 dBu Output (Buss Output)
Dimensions (W x D x H)	482 x 435 x 148 mm
Weight	8.7 kg
Power Requirements	120 V AC 60 Hz 230/240 V AC 50/60 Hz
Power Consumption	44 w 46 w

Notes
